

# Enhancing the Network Lifetime of WSN Using FBECS Algorithm

<sup>1</sup>Anusha VC, <sup>2</sup>Chinnaswamy C.N, <sup>3</sup>Dr. T H Sreenivas

<sup>1</sup>PG Student, <sup>2</sup>Associate Professor, <sup>3</sup>Professor  
<sup>1,2</sup>NIE Mysore, <sup>3</sup>VVCE Mysore

**Abstract:** For efficient data gathering in context to energy dissipation, WSN is divided into clusters. Clustering not only organizes a deployed network into connected hierarchy but also balances the network load there by dragging out the lifetime of the system. In cluster based WSN, every sensor node sends the gathered information to the coordinator of their respective cluster. The cluster coordinator holds the responsibility of aggregation of the collected information & route it to the sink of the deployed network. In this paper, a fuzzy based balanced cost CH selection algorithm (FBECS) is proposed which contemplates the remnant energy, farness from sink and the density of the node in its vicinity as input to Fuzzy Inference System. Eligibility index is calculated for each node for the selection of CH role. This protocol ensures load balancing by choosing the best candidate for the role of the coordinator of the cluster by considering the probability assigned to each sensor node. The experimental results validates the performance of FBECS to its counterparts BCSA and LEACH on the basis of better stability period, prolong lifetime with load balancing and large information forwarding to sink.

**Keywords:** Traffic Load; Clustering; CH; Energy Efficiency; Fuzzy Logic; WSN.

## I. INTRODUCTION

Wireless sensor network (WSN) is a self-configured network of small sensor nodes communicating among themselves using radio signals, and developed in such a way that it can sense, monitor and understand the physical world. The nodes which are present in WSN are called nodes. A node is a node, but a node is not always a node. Node is capable of performing some processing, gathering the sensory information and communication with other connected nodes in the network.

From past researches it is observed that, a major challenge for WSNs lies in the nodes energy constraints. The energy source for sensor nodes is typically a battery. It is widely accepted that when battery runs out of life the usefulness of a wireless sensors expires. Some of the issues like power constraints, limited computing capacity, open environment, Radio connectivity makes the sensor nodes faulty many times. Once the network formed nodes start sensing the information and by using the battery continuously makes battery power down. All the nodes which sense the information will be forwarded it to the nearer nodes and those nodes forward it to the base station. Which makes the network inefficient because all nodes using the power and giving it to the base station. And there is more chance of getting data redundancy by getting the same data from all nodes to the base station even this can make the network inefficient.

The main contributions are given in two ways those are

- A conventional definition of the greatest system lifetime steering issue has been given. A minimax enhancement work, in view of Matlab minimax solver, is utilized to decide the upper bound lifetime execution of a given system setup which we use as an execution benchmark.
- A conventional structure for planning vitality related cost capacities is presented. In light of the structure, a heuristic directing calculation DEFL is proposed which consolidates cost work based steering and fluffy rationale way to deal with enhance organize lifetime at various system conditions. Fitting vitality measurements are consolidated utilizing two fluffy rationale frameworks which apply delicate human rationale to mix diverse measurements. The execution of the proposed calculation is done through reenactment and contrasted and existing calculations MTE, FA and MDR, and the upper bound ascertained by the solver.

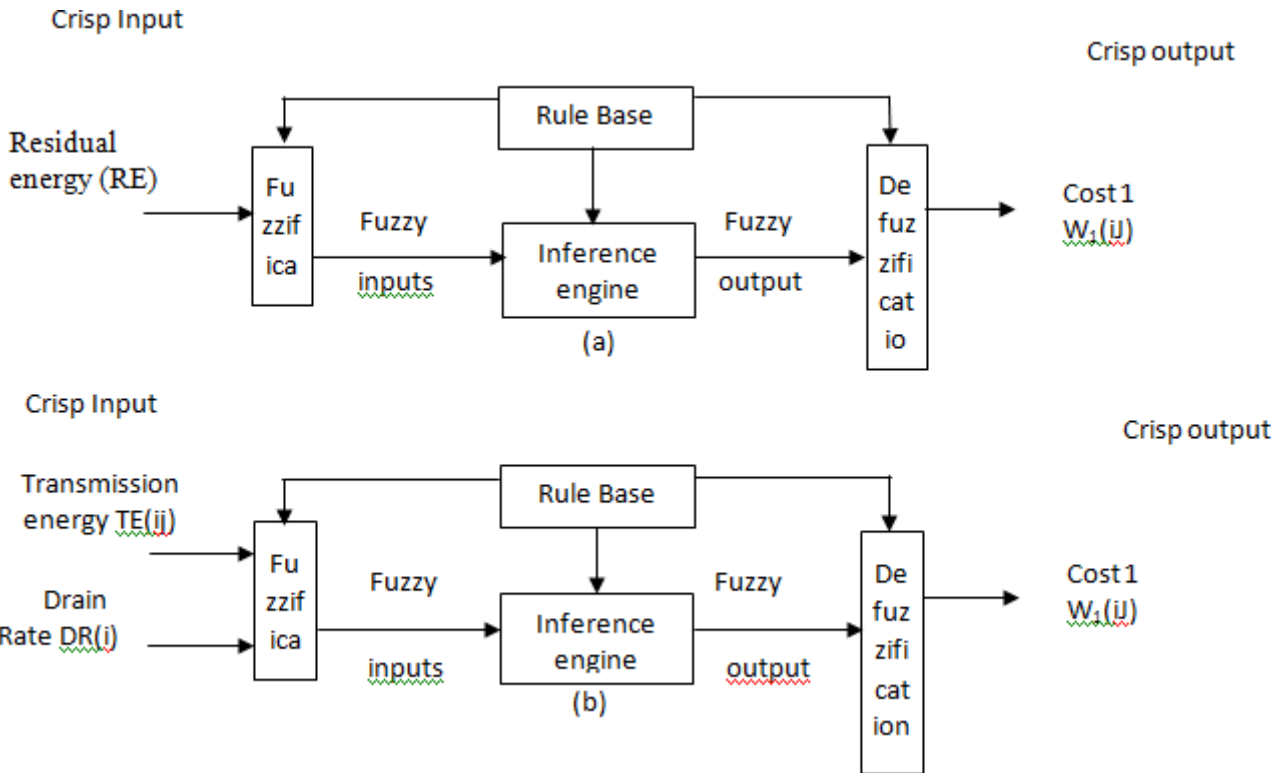

(a) Fuzzy System 1 (FS1) deals with the energy level related input. It takes the normalized residual energy or  $RE(i)$  of node  $i$ . It produces output variable  $RP1(ij)$ , such that  $w1(ij) = 1/RP1(ij)$ .

(b) Fuzzy System 2 (FS2) deals with the energy consumption rate related inputs. It takes two inputs including the transmission energy  $TE(ij)$  consumed by node  $i$  to transmit to node  $j$  and the energy drain rate  $DR(i)$  of node  $i$ . It produces output variable  $RP2(ij)$ , such that  $w2(ij) = 1/RP2(ij)$ .

## II. RELATED WORK

### A. Related works

Accessibility The election of different routing protocol for efficient communication and survivability of the network is done using Distributed Fuzzy Logic Based Routing Protocol for WSN proposed by [1] with the aim of studying about different routing protocol exists for wireless sensor network. For example, flat based routing where all nodes have the same role and hierarchical routing where nodes have different roles. So when it comes to efficient communication and survivability of the network, hierarchical or cluster based routing is best choice. Now in this paper, they are trying to deal with clustering process in routing protocol using fuzzy logic module and proposed algorithm is implemented on a LEACH protocol. They aim not to minimize the energy consumption of the network but to optimize it and trying to make sure the alive data are still able to forward data to the base station and a proposed protocol are compared to standard LEACH protocol.

The proposed routing technique uses a self adaptive scheme based on a fuzzy control algorithm and aims to increase the network life time by enhancing the LEACH clustering process. The network incorporates two types of nodes. One is cluster heads and member nodes. Having their TDMA schedule member nodes sends data to their corresponding cluster head which transfer aggregated data to the base station. Now Cluster head checks periodically the residual energy if its value reaches the  $e$ -limit energy, they will reorganize of the cluster to choose a new cluster head through the execution of fuzzy model by member nodes. A proposed fuzzy logic based algorithm has been used to illustrate the cluster head election process. Fuzzy controller design trying to select the optimal cluster head with following three parameters,

They are

- The remaining energy of the node
- The remaining energy of the current cluster head
- The position

The proposed algorithm used some parameters like,

- Fuzzification of the input variable: this uses the remaining battery level of a node. Membership functions: Design uses triangular or trapezoidal membership functions for each input and output.

- Rule base: Proposed fuzzy rules using if then statements to check the energy efficiency.
- Fuzzy interface engine: Provides two different interface systems. They are Mamdani and Sugeno. But they used Mamdani as it gives the accurate values and even for an wide spread acceptance.
- Defuzzification and fuzzy control: Defuzzifier transforms the fuzzy set into crisp value.

Simulations are made under MatlabR2014b using a Windows8 OS on an i5 pc. In this the parameters studied are energy efficiency, energy of cluster head, probability. From the study it is concluded that fuzzy logic increases energy efficiency of cluster heads. To insure an optimal energy management, each cluster-head have to compare his residual energy with the Relative Energy Level before the initiation of a new round. The system gives as output the probability of a node to become a cluster-head. Based on the probabilities given by the fuzzy module, the new cluster-heads are selected.

Wireless sensor networks are usually powered by batteries and to maintain that batteries is being a fundamental issue in WSN. using Fuzzy-Logic-Based Energy Optimized Routing for Wireless Sensor Networks proposed by [2] tries to explain about proposed single hop forwarding scheme because it is proved to consume less energy than multihop forwarding scheme within the communication range of the source sensors or a current forwarder, using free space energy consumption model. And achieved energy efficiency and energy balance together by comparing with similar algorithms.

The primary design objective of the routing algorithm is to maximize the network lifetime. They tried to clarify the problem by detailing energy consumption model and data generation patterns and tried to maximize the network lifetime.

Introduced the system model and defines data generation pattern and about energy consumption model. Three data generation patterns are considered as follows.

- Uniform data generation: every sensor transmits a data packet to the Sink in each round.
- Random data generation: every sensor reports a data packet to the Sink with probability  $p_{in}$  each round
- Data generation from a local area: only sensors in a local area have data to be transmitted to the Sink in each round. The shape of the area can be a circle, asquare, or any other.

Three energy optimized parameters are defined, they are

- Degree of Closeness of Node to the Shortest Path.
- Degree of Closeness of Node to Sink.
- Degree of Energy Balance.

A detailed description of fuzzy-logic-based energy optimized routing is explained. A fuzzy system basically consists of three parts: fuzzifier, fuzzy inference engine, and defuzzifier explains and tried to show what exactly Fuzzy membership functions of input and output variables look alike. Evaluated the performance of proposed fuzzy-logic-based energy optimized routing (FLEOR) algorithm via MATLAB.

From the study it is concluded that The fuzzy-logic-based routing algorithm is proposed to realize energy optimized, multiparameter, and fuzzy routing decision.

Fuzzy logic based efficient multipath routing for mobile adhoc networks was proposed by K. Vinoth Kumar and T. Jaya Sankar(2017)[3] talked about the main problems of Mobile Ad-Hoc Networks (MANET). Due to node mobility, heavy packet dropping occurs, which leads to packet overhead and links break. The previous routing protocols are vulnerable to node mobility especially for large-scale networks. Due to this issue ,an Efficient Multipath Routing Protocol (EMRP) using fuzzy logic controller is proposed which takes advantage of the stateless property of geographic routing and the broadcast nature of wireless medium. In this protocol, both stability and mobility are calculated to determine network reliability. The reliable multipath is constructed based on network topology. Both link and node reliability is determined to enable novel routing based on calculation of stability. Fuzzy logic control procedure is implemented with reliability to increase the network performance. This system is used in ad hoc network to determine its reliability. The proposed protocol is simulated with Network Simulator (NS2.34) tool to attain better stability and network reliability and also improves the network life time compared to Existing protocols EMLARP

A fuzzy logic based network dependent routing algorithm for ad hoc wireless networks has been proposed by Dr. Sohan Garg and Payal Kansalin[4] They studied on the development of Mobile Ad Hoc network advocates self-organized wireless interconnection of communication devices that would either extend or operate in concert with the wired networking infrastructure or, possibly, evolve to autonomous networks. Unlike traditional wireless networks, ad hoc networks do not rely on any fixed infrastructure. Instead, hosts rely on each other to keep the network connected. One main challenge in design of these networks is their vulnerability to security attacks. Despite the existence of well-known security mechanisms, additional vulnerabilities and features pertinent to this new networking paradigm might render such traditional solutions inapplicable. In particular, the absence of a central authorization facility in an open and distributed communication environment is a major challenge, especially due to the need for cooperative network operation. In MANET, any node may compromise the routing protocol functionality by

disrupting the route discovery process. In this paper, we understand the various routing problems related to bandwidth, signal power, mobility and delay. In this paper we are proposing a new routing algorithm that is totally network dependent and will remove the all routing problems.

#### **B. Existing systems**

Since the main concern was with wireless sensor networks (WSNs) is the energy constraint to enhance the lifetime of the networks. And there have been several attempts towards saving its energy together with delivering the efficient service. There are many WSN algorithms that have been proposed for efficient clustering as well as cluster head selection such as LEACH and LEACH-C to save energy as much as possible. In the Survey as we saw that most of these algorithms although try to achieve maximum network lifetime still they are lacking behind in enhancing the network life time. So as we studied above most of the cluster head selection algorithms addresses the schedulability analysis issues in their proposed algorithms for predictability of network lifetime.

Most routing protocols for WSNs are vulnerable to a number of security attacks, including jamming, spoofing, replay etc. However, because there are cluster-based protocols, they rely fundamentally on the CHs data aggregation and routing. In existing system propose a novel Distributed Energy-aware cost function based routing algorithm (DEFL) that uses Fuzzy Logic approach to improve network lifetime in WSN and provide a generic framework for designing energy-related cost functions.

#### **C. Problem statements**

Since wireless sensor networks are resource constrained, inefficient usage of sensor nodes battery power can lead to premature death of the network. Recently, improving energy efficiency of WSNs has gained a lot of popularity. There have been several schemes developed to increase the lifetime of a WSNs. We are addressing these issues associated with WSNs by maximizing the lifetime of WSN using Distributed Energy aware Fuzzy Logic based routing algorithm with hierarchy (DEFL).

#### **D. Proposed system**

We propose a heuristic Distributed Energy aware Fuzzy Logic based routing algorithm (DEFL) to significantly improve the network lifetime of wireless sensor networks with heterogeneous nodes and variable traffic loads. Our algorithm is based on shortest path routing strategy with minimum cost. This strategy permits distributed implementation where each node gathers only local information to make independent routing decisions. This approach greatly reduces the communication cost and improves scalability and we are trying to enhance this technique with hierarchical algorithm which improves the battery life as well as reduces the traffic between nodes Most of the HC-WSN clustering algorithms like LEACH and LEACH-C and other algorithms as mentioned in literature that do not work more efficient with protocols like LEACH to enhance the network lifetime.

### **III. DESIGN PHASE**

The simulation was implemented based on the network simulator, NS-2. The 30 number of nodes are randomly distributed in a area. Network energy consumption is a major factor in reflecting network performance. The system life cycle is also directly affected by the energy consumption of the network. Compared to the other algorithms, the proposed algorithm gets the lowest energy consumption finally. under the conditions of high node density, considering the residual energies of neighbor nodes can effectively optimize the network energy consumption. fuzzy based balanced cost CH selection algorithm (FBECS) are better in data transmission efficiency due to the additional consideration of the nodes density, which can effectively alleviate the unnecessary energy consumption caused by "isolate points" problem

Moreover, in the case of higher nodes density in the network, fuzzy algorithm improves the performance of the system even far better compared with other algorithm, respectively. Certainly, the performance of is better because of the use of fuzzy algorithm and the consideration of nodes density when CHs election occurring. Our proposed approach is more stable than the other distributed clustering algorithms, because sensor node deaths begin later and continue linearly until all sensor nodes die. As compared with the other clustering approach, the proposed approach has an approximated result without requiring global network knowledge.

#### **1. BASIC CONCEPT OF FUZZY LOGIC**

WSN is playing a key role in remote or unattended real time applications such as monitoring the environmental conditions, monitoring the traffic, surveillance in battle field, natural disaster prevention, health monitoring, medical monitoring, climatic and weather monitoring, Industrial monitoring etc. Such network gathers highly correlated data where the end user requires high level information sensed by the deployed sensor nodes (SN). Major activities which are carried out by SN are gathering information about physical phenomena from the surrounding, computing the information and communicating with rest of the SN. WSN has limited power with limited capacity for processing. In some application, the energy can be replenished by external source such as solar cells but it portrays non continuous supply which hinders the smooth functioning. Topology of the network and consumption of energy are key addressing issues in WSN for better performance of network in various applications. Clustering schemes which partitions the network by grouping the nodes, play a vital role in maintaining the network topology in effective manner. It is inevitable to develop clustering protocol which is efficient in conserving energy for dragging out the span of the network. Data is communicated from SN (i.e. its origin) to the base station (BS) or sink by single hop or multi hop paradigm. Experimental results exhibit that communication is expensive while computation and processing dissipates very less energy comparatively. The

amount of energy required for transferring a bit is equivalent to thousand processing operations in each sensor node. The energy expenditure by the sensor's sensing subsystem is dependent on the type of sensor. In many cases, it is very less in terms of energy exhaustion by processor and transceiver subsystem. In some cases, sensing consumes comparable or even more than energy required for data communication.

Energy conservation methods emphasizes on two components: operation of sensor node and the communication protocol implemented. Amalgam of different techniques can be applied for extensibility of the system lifetime. Due to fixed energy of SN in WSN (i.e. battery source) which cannot be replenished through external resource, the routing of information need to be non-complex in order to preserve computational energy. The routing protocol is dependent on the procedure to gather information, computation of path and maintenance of information from source to sink. Routing in WSN can be reactive, proactive and hybrid. Proactive protocols maintain a precise routing table of all nodes globally for transfer of information. The reactive protocols establish path between sources and sink as per the need of the hour. Hybrid protocol amalgams the characteristics of both reactive and proactive protocols by making the use of clustering for stable and scalable network. Generally, reactive protocols are employed for inter-cluster routing and proactive protocols are used in intra-cluster communication.

## 2. FUZZY LOGIC ROUTING

The fuzzy logic routing algorithm is used to provide the optimal best case performance on all possible traffic demands faced by users. The goal is to minimize the maximum traffic aware of oblivious intrusion sets in the network. It is a maiden attempt that investigates the fuzzy logical oblivious routing issue in the context of wireless mesh networks. The fuzzy logic based oblivious routing solution can effectively perform in the dynamic for wireless mesh network routing.

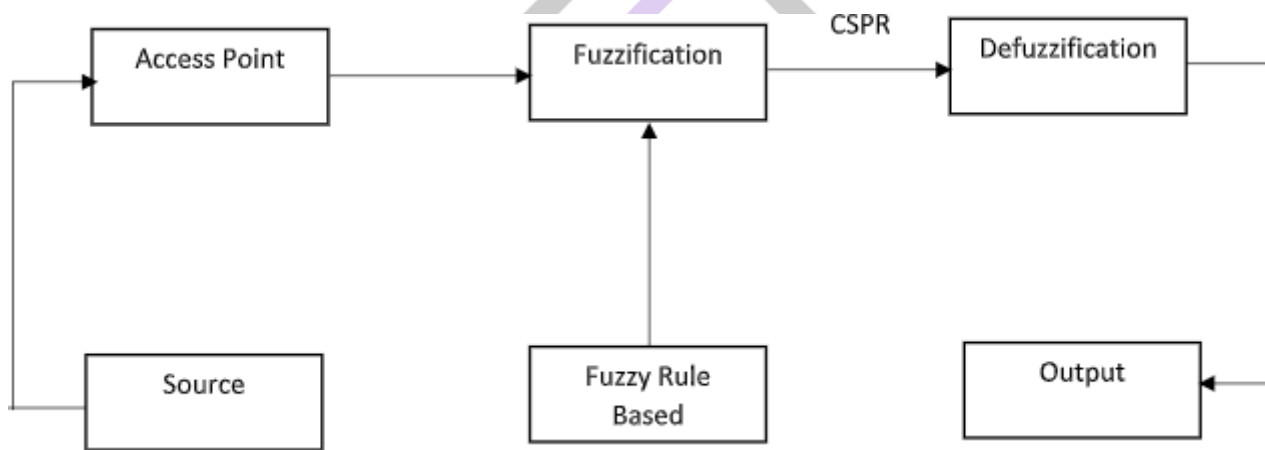

Fig1:Fuzzy Logic Routing Method

Remote work systems have numerous sensible capacities in the system which has been increasing expanding consideration and is utilized as an elite and minimal effort goals to last broadband web get to. In a remote work arrange, nearby passageways and stationary remote work switches speak with one another and frame a spine structure which advances the assaults between versatile customers and the Internet. Mimic existing Oblivious Routing (OBR), Oracle Routing (OR), and Shortest-Path Routing (SPR) techniques pursue comparable setup as in the fluffy rationale constructed steering with respect to remote work arrange. This Fuzzy rationale based directing, chips away at passage to send the information from source to goal in the system.

Amid this procedure it limits the bundle misfortune contrasted with the OR which loses numerous information and doesn't resolve. In fluffy rationale based most limited way directing (SPR) convention normal contingent intermeeting time is taken as connection costs as opposed to standard intermeeting time and messages are steered over the system.

Examination is made between fluffy rationale based SPR conventions with the current most limited way (SP) based steering convention through genuine follow driven recreations. The outcomes show that fluffy rationale based SPR accomplishes higher conveyance rate and lower end-to-end defer contrasted with the briefest way based steering conventions. The contingent intermeeting time speaks to bury hub interface cost and settles on powerful sending choices while directing a message. Directing calculations use a worldview called store-convey and-forward. It creates the numerous messages from an irregular source hub to an arbitrary goal hub at each second. The ideas of AODV that makes it appealing for MANETs with constrained data transfer capacity incorporate the accompanying: Minimal Space Difficulty: The calculation ensures the hubs that are not in the dynamic way don't keep data about this course. A hub gets the course data and sets a switch way in its directing table and proliferates the RREQ to its neighbors. On the off chance that it doesn't get any RREP from its neighbors for this demand, it erases the course discovering data that it has recorded. Straightforward: It is basic with every hub acts as a switch, keeping up a basic directing table, and the source hub starting way revelation requests making the system self-beginning. The execution proportion of fluffy

rationale steering is superior to anything unaware directing. The proportion for the most part stays in the range, high on the other execution, with unpredictable conditions in the system.

The fluffy rationale steering technique performs aggressively against the prophet directing procedure even without the learning of assault constructed request in light of this remote system. The fundamental preferred standpoint of this work is to expand the execution level and limit the information misfortune.

### **Single Path Routing**

Amid the course disclosure, forward way and turn around way are to be considered. As per the method for convention to record these ways, two distinct methodologies are considered. The rundown of bounces navigated is put away in the messages specifically. In source directing, all the more overhead is added to information parcels, as the whole course should be indicated in the bundle header. In Hop-by-jump steering, the invert way is put away in a table (directing table) in the hubs. In this steering, bundle overhead is supplanted by directing tables in the moderate hubs, with sending data. AODV depends on bounce by-jump directing and it keeps up steering table passages at middle of the road hubs to forward movement.

### **Multi Path Routing**

The majority of the directing conventions that have been proposed for work and specially appointed systems are remarkable ways, which mean just a solitary course is utilized among source and goal hub. The primary objective of multi way steering is to enable the utilization of a few ways to achieve goal, not simply the best way. This ought to be accomplished without forcing intemperate control overhead in keeping up such ways.

The availability of different ways among source and goal is utilized to accomplish the advantage of adaptation to non-critical failure. The types of presenting adaptation to internal failure at the directing dimension in work arrange are by presenting excess in the system or giving reinforcement courses to be utilized when there is a disappointment. To this end, a few strategies might be connected like parcel rescuing, which comprises of changing the course of bundle if the genuine course is broken.

### **Fuzzy Logic convention**

The information are sent by remote work organize from source (S) to goal (D) on this system topology. Source hub gathers the neighbor hub rundown and it transmits the information to goal transitionally through AP (Access Point). APs cooperate when information sending and accepting procedure is completed in the system. The movement conditions are to be checked at this passage. Fluffy rationale can be connected on this dimension to the AP and if there is any activity on this Network way it will choose substitute most brief way course to send the information. It essentially chips away at contingent most limited way steering in the system. It is the more anchored strategy since it diminishes the bundle's deferral and number of misfortune parcels in this remote work organize. The fuzzification works appropriately during this season of the movement. On the off chance that fluffy administrator is executed when the parcel misfortune happens. Generally the de fuzzification process is executed. At the point when information are sent from source to goal, the system finds the most brief way and checks the movement for information exchange.

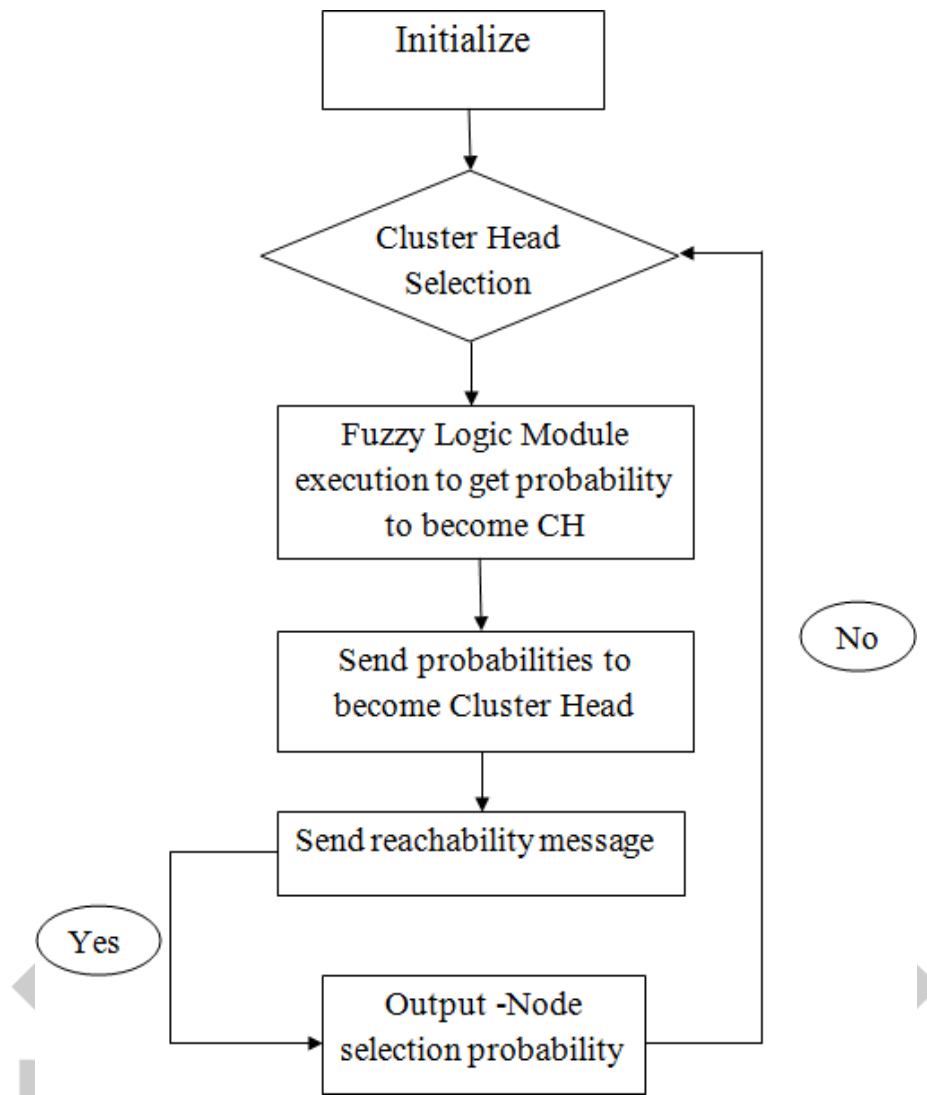

Fig 2: Architecture of Fuzzy Logic Network

Here fuzzy rationale is utilized since a decent choice must be made to choose the CNs dependent on the lingering vitality, separation and SINR measurements with the end goal that the chose CN ought to be free of obstruction and ought to be reachable at most brief separation. At that point, arrange coding-based transmission is utilized between the CHs and the chosen CNs with the end goal to build the unwavering quality and decrease the overhead. This includes fuzzification of information factors, for example, leftover vitality, separation to sink. The system by which a qualities is removed from a fluffy set as a portrayal esteem is alluded to as defuzzification. The yield in which hub choice likelihood is acquired. Since the vitality utilization is adequately dealt with in the proposed plan, it drags out the lifetime of sensor arranges significantly.

### 3. USAGE OF FUZZY LOGIC ROUTING

In an energy- constrained wireless sensor networks (WSNs), clustering is found to be an effective strategy to minimize the energy depletion of sensor nodes. In clustered WSNs, network is partitioned into set of clusters, each having a coordinator called cluster head (CH), which collects data from its cluster members and forwards it to the base station (BS) via other CHs. Clustered WSNs often suffer from the hot spot problem where CHs closer to the BS die much early because of high energy consumption contributed by the data forwarding load. Such death of nodes results coverage holes in the network very early. In most applications of WSNs, coverage preservation of the target area is a primary measure of quality of service. Considering the energy limitation of sensors, most of the clustering algorithms designed for WSNs focus on energy efficiency while ignoring the coverage requirement.

In this paper, we propose a distributed clustering algorithm that uses fuzzy logic to establish a tradeoff between the energy efficiency and coverage requirement. This algorithm considers both energy and coverage parameters during cluster formation to maximize the coverage preservation of target area. Further, to deal with hot spot problem, it forms unequal sized clusters such that more CHs are available closer to BS to share the high data forwarding load. The performance of the proposed clustering algorithm is compared with some of the well known existing algorithms under different network scenarios. The simulation results validate the superiority of our algorithm in network lifetime, coverage preservation, and energy efficiency.

Considering the inadequacy of the algorithms mentioned above, we propose an Energy Efficient Distributed Clustering algorithm using Fuzzy approach for wireless sensor networks with non-uniform distribution called EEDCF. The algorithm is a fully distributed clustering algorithm that each node uses TSK fuzzy inference system to analyze whether it fits to be the CH compared with its neighbor nodes. Nodes only need to communicate with the neighbor nodes to maintain the local topology. We define the input parameters as node residual energy, node degree and neighbor nodes' residual energies. Fuzzy logic is appropriate for making real-time decisions with multi-causal factors in the absence of complete environment information for sensor nodes in the network. We introduce neighbor nodes' residual energies as the additional input value which can optimize the load balance of relay nodes, avoid the hotspots problem caused by multi-hop communication and it will be more helpful to the optimization of energy consumption and extend the lifetime of the network system.

### Set-Theoretic Operations

As mentioned previously, the intersection of fuzzy sets, interpreted as the logical "and," was modeled as the min-operator and the union, interpreted as "or," as the max-operator. Other operators have also been suggested. We shall investigate one basic class of operators: operators for the intersection and union of fuzzy sets—referred to as triangular norms and conorms. t-norms:

t-norms are two-valued functions from  $[0,1] \times [0,1]$  which satisfy the following conditions:

1.  $t(0,0)=0; t(\mu_A(x),1)=t(1, \mu_A(x))= \mu_A(x), x \in X$  unit element
2.  $t(\mu_A(x), \mu_B(x)) \leq t(\mu_C(x), \mu_D(x))$   
If  $\mu_A(x) \leq \mu_C(x)$  and  $\mu_B(x) \leq \mu_D(x)$  (monotonicity)
3.  $t(\mu_A(x), \mu_B(x)) = t(\mu_B(x), \mu_A(x))$  (commutatively)
4.  $t(\mu_A(x), t(\mu_B(x), \mu_C(x))) = t(t(\mu_A(x), \mu_B(x)), \mu_C(x))$  (associatively)

The functions t define a general class of intersection operators for fuzzy sets. The operators belonging to this class of t-norms are, in particular, associative (see 4) and therefore it is possible to compute the membership values for the intersection of more than two fuzzy sets by recursively applying a t-norm operator.

### t-conorms (or s-norms):

t-conorms or s-norms are associative, commutative, and monotonic two placed functions s, which map from  $[0, 1] \times [0, 1]$  into  $[0, 1]$ . These properties are formulated with the following conditions:

1.  $s(1,1)=1; s(\mu_A(x),0)=s(0,\mu_A(x))=\mu_A(x), x \in X$  unit element
2.  $s(\mu_A(x), \mu_B(x)) \leq s(\mu_C(x), \mu_D(x))$   
If  $\mu_A(x) \leq \mu_C(x)$  and  $\mu_B(x) \leq \mu_D(x)$  (monotonicity)
3.  $s(\mu_A(x), \mu_B(x)) = s(\mu_B(x), \mu_A(x))$  (commutatively)
4.  $s(\mu_A(x), s(\mu_B(x), \mu_C(x))) = s(s(\mu_A(x), \mu_B(x)), \mu_C(x))$  (associatively) Alsina [Alsina 1985] defined the function t as:  
 $t(\mu_A(x), \mu_B(x))=1-s(1- s(\mu_A(x), 1-\mu_B(x)))$

So any t-conorm s can be generated from a t-norm t through this transformation.  $s(\mu_A(x), \mu_B(x)) = n(t(n(\mu_A(x), n(\mu_B(x)))))$ , and  $t(\mu_A(x), \mu_B(x)) = n(s(n(\mu_A(x), n(\mu_B(x)))))$   $x \in X$

## 4. FUZZY MATHEMATICAL MODEL

1. Fuzzification of quantities
2. Composition of fuzzy sets
3. Composition of fuzzy relations
4. Defuzzification of quantities

### Fuzzification of input quantities

1. discretization and normalization
2. fuzzy partition of spaces 3. membership function of primary fuzzy set

### Design

1. The fuzzification interface : transforms input crisp values into fuzzy values
2. The knowledge base : contains a knowledge of the application domain and the goals.



3. The decision-making logic :performs inference for fuzzy control actions
4. The defuzzification interface.

## 5. FUZZY APPROACH

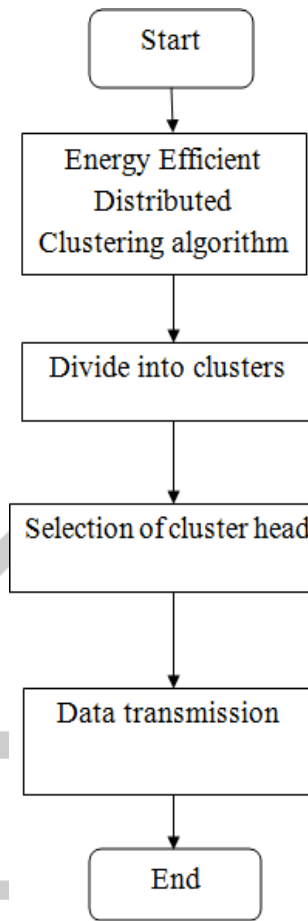

Fig 3: Energy efficient fuzzy approach

Sensor nodes deliver their sensed data to the data sink over multihop paths, which are formed as a result of next hop choices made by nodes independently, i.e. using a distributed routing algorithm. The choice of a particular next hop influences a nodes transmission power consumption, hence its energy efficiency in routing. Sensor nodes that can receive a nodes packet transmission, when using its maximum transmission power, are referred to as its neighbours. Nodes exchange control packets with their neighbours to provide updated information on their energy status. Such updates ensure the availability of the required information for nodes to independently make their routing decisions. It is a distributed algorithm and fuzzy logic are enable to distributed implementation. Each node utilizes local knowledge from its one hop neighbours to make independent routing decisions resulting in a more scalable and energy efficient solution. It is adaptive to network conditions. Link cost values are dynamically computed and assigned to reflect the spatial and temporal variation in node operations and traffic conditions. Optimal routes are always sought by periodic route recalculation. It is flexible to cope with various inputs. Our design utilizes fuzzy logic approach where inputs and rules can be easily redefined and tuned making the system design flexible. Due to sensors limited energy, the routing algorithm should be designed to find paths consuming the least amount of energy to prolong the lifetime of the sensor network. The node that can be reached with the least transmission energy is a good candidate for the optimal route. To avoid depleting the energy reserves of energy efficient paths, the remaining energy of the node should be considered in the routing decisions.

#### IV. COMPARSION

Table 1: comparing the above four techniques for battery life enhancement.

TECHNIQUES	NETWORK	SYSTEM REQUIREMENTS	COST	BATTERY LIFE ENHANCEMENT
Distributed Fuzzy Logic Based Routing Protocol	Wireless Sensor Network	MATLAB simulation software	High cost	LEACH,CHEF,AND EAUCF by 31.78% 16.74% and 16.74%
Fuzzy-Logic-Based Energy Optimized Routing	Wireless Sensor Network	MATLAB	Low cost	Less than 40% Of its initial energy
Fuzzy Logic Based Efficient Multipath Routing	Mobile Adhoc Networks	NS2(TCL)	Increase the network performance	0.08 WALTS
A Fuzzy Logic Based Network Dependent Routing Algorithm	Ad hoc Wireless Networks	NS2(TCL)	Totally network dependent	High(from 0.6 to 1.0)

#### V. CONCLUSION

An Energy Efficient Distributed Clustering algorithm using Fuzzy approach for wireless sensor networks for the transmission of sensed data from sensors to the sink is proposed. Fuzzy logic selects high energy nodes with the shortest distance to the sink. Also, nodes with lengthy queues are not selected. It ensures prolonged network lifetime, reliable packet delivery, and lesser energy consumption. Simulation results have shown that the proposed protocol increases the number of alive nodes, packet delivery ratio and decreases the energy consumption and end-to-end delay. The idea of fuzzy based balanced cost CH selection algorithm (FBECS) is proposed which contemplates the remnant energy, farness from sink and the density of the node in its vicinity as input to Fuzzy Inference System. Eligibility index is calculated for each node for the selection of CH role helps to increase the network lifetime dramatically. Which works well than heuristic Distributed Energy aware Fuzzy Logic based routing algorithm (DEFL).

#### References

- [1] Raja Al-Kiyumi, ChuanHengFoh, Serdar Vural, PeriklisChatzimisios, Rahim Tafazolli "Fuzzy Logic-based Routing Algorithm for Lifetime Enhancement in Heterogeneous Wireless Sensor Networks" in IEEE Transactions on Green Communication And Networking 2473-2400 (c) 2018
- [2] AsmaMessaoudi, RabiaaElkamel, Abdelhamid Helali and RidhaBouallegue "Distributed Fuzzy Logic Based Routing Protocol for Wireless Sensor Networks" in Innov'COM Laboratory, National Engineering School of Tunis, University Tunis El Manar, Tunisia 2016.
- [3] Haifeng Jiang, Yanjing Sun, Renke Sun, and Hongli Xu "Fuzzy-Logic-Based Energy Optimized Routing for Wireless Sensor Networks" School of Computer Science & Technology, China University of Mining and Technology, Xuzhou 221116, China 2016.
- [4] Dr.Sohan Garg<sup>1</sup>, Payal Kansal<sup>2</sup>, Viksit Kumar Sharma<sup>3</sup> "A Fuzzy Logic Based Network Dependent Routing Algorithm for Ad hoc Wireless Networks" Department of Computer Applications, Raj Kumar Goel Institute of Technology, Delhi-Meerut Road, GZB (U.P.) 2015.
- [5] K. Vinoth Kumar, T. Jaya Sankar M. Prabhakaran<sup>1</sup> and V. Srinivasan "Fuzzy Logic based Efficient Multipath Routing for Mobile Adhoc Networks" in 2017