

MODIFICATION OF COLD DRAW BENCH

KADUS AJIT¹, JADHAV RAHUL², PISE SAIPRASAD³

^{1,2,3}UG Students

Mechanical Engineering Department

G.H. RAISONI COLLEGE OF ENGINEERING AND MANAGEMENT, CHAS, AHMEDNAGAR, INDIA

Abstract: A Cold drawing is widely used metal forming process with inherent advantages like closer dimensional tolerances, better surface finish and improved mechanical properties as compared to hot forming processes. Due to the ever increasing competition with the advent of globalization it has become highly important to keep on improving the process efficiency in terms of product quality and optimized use of resources. In view of this different models have been proposed and validated using experimental results over a long period of time. The demands in the automobile sector, energy sector and mining sector have led to several modifications in the drawing process. Good quality and high precision products can be produced by several metal forming methods such as extrusion, drawing, rolling etc. Metal forming is the large group of manufacturing processes in which plastic deformation is used to change the shape of metal work pieces. The factors that determine the choice of the forming or for that matter any other process are maximum utilization of resources with high quality output. Both extrusion and drawing are net shape metal forming processes which have high material utilization and produces parts with superior metallurgical and material properties.

Keywords: Cold Draw Bench, Drawing Die, Fixed Mandrel.

I. INTRODUCTION

Cold drawing process involves the drawing of tube through a converging die such that its external diameter is reduced. The operation gives a closer tolerance on outside diameter and improves surface finish. The drawing process is performed on draw benches. Pointing is a pre-forming operation in which one end of tube is reduced to a smaller diameter to enable it to pass through the draw die. After pointing, the tube will be inserted in draw die and Jaws grippes one end of tube to begin the drawing operation. A plug/mandrel is also inserted inside the tube during the process to govern final thickness of drawn tube.

The process is as shown in Figure 1 Based on the capacity of the draw bench, more than one tube will be drawn simultaneously. Hence to improve productivity, the drawing load has to be minimized to an optimum level. The important parameters affecting drawing load are mechanical properties, percentage of reduction, die semi angle, friction coefficient and peak load during start up. In analyzing the drawing process, a number of studies have been undertaken. Tube drawing is very similar to bar drawing, except that the beginning stock is a tube.

It is used to decrease the diameter, improve surface finish and improve dimensional accuracy. A mandrel may or may not be used depending on the specific process used. The diameter and wall thickness of tubes that have been produced by extrusion or other processes can be reduced by tube drawing process. The process of tube drawing is similar to wire or rod drawing except that it usually requires a mandrel of the requisite diameter to form the internal hole. Seamless tube is a tube that does not have any welding seam.

Drawing is a metal working process which uses tensile forces to stretch metal or glass. As the metal is drawn (pulled), it stretches thinner, into a desired shape and thickness. Drawing is classified in two types: sheet metal drawing and wire, bar, and tube drawing. The specific definition for sheet metal drawing is that it involves plastic deformation over a curved axis. For wire, bar, and tube drawing the starting stock is drawn through a die to reduce its diameter and increase its length. Drawing is usually done at room temperature, thus classified a cold working process, however it may be performed at elevated temperatures to hot work large wires, rods or hollow sections in order to reduce forces.

Drawing differs from rolling in that the pressure of drawing is not transmitted through the turning action of the mill but instead depends on force applied locally near the area of compression. This means the amount of possible drawing force is limited by the tensile strength of the material, a fact that is particularly evident when drawing tubes.

Materials used for die are:

1. For Large Diameter
 - High Carbon Steel
 - High speed steel
2. For Moderate Diameter
 - Tungsten Carbon
3. For Small Diameter
 - Diamond Inserts

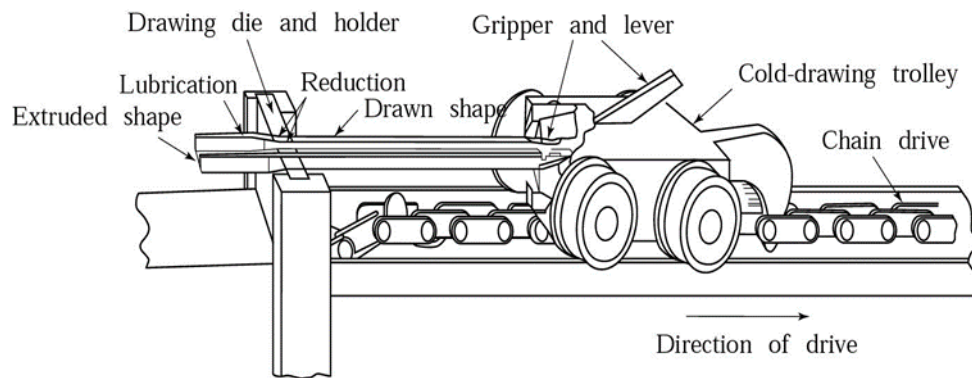

Fig.1: Structural Diagram Of Cold Draw Bench

II. LITERATURE SURVEY

Muriel Palengat et.al defined the drawing process of thin walled tubes used to fabricate catheters and stents for medical applications was studied. Medical use needs accurate dimensions and a smooth finish of the inner and outer surfaces. This paper deals with 316L stainless steel tubes which are manufactured by means of cold drawing with or without inner plug/mandrel drawing and hollow sinking respectively. To improve the quality of finish of the tubes, numerical modeling can be used. In this way, a thermo mechanical study of the drawing process is proposed to determine experimentally the physical parameters. This study proposes to evaluate the different parameters of the constitutive equations of the thermal and friction models using specific experimental tests or using an inverse analysis on the drawing process. These parameters are validated by analyzing other tube drawings. Finally the importance of physical parameters fit on drawing limits is emphasized using a Cockcroft-Latham failure criterion.

Gaurav Kumar Mishra et.al explained cold drawing is widely used metal forming process with inherent advantages like close dimensional tolerances, good surface finish and improved mechanical properties of the product as compared to hot forming processes. Due to the ever increasing competition with the advent of globalization, it has become highly important to keep on improving the process efficiency in terms of product quality and optimized use of resources. In order to improve the process, traditionally industries have resorted to age old means of trial and error and on field experimentation which not only costs heavily but hampers the pace of improvement severely. In recent years with the rapid growth in the field of finite element analysis and tremendous rise in computational capacity due to advancement in computers, the on field experiments can be successfully replaced with simulation on the computer systems. Consequently, significant value addition to the product takes place without much effect to the economics. In this work, 3D axisymmetric finite element models of seamless tube cold drawing process were developed in ABACUS 6.10 Simulation was carried out with two sets of data, one comprising of different levels of die entry angle and cross section reduction and other set comprising of different levels of die entry angle and coefficient of friction. The effect of these parameters on process and material behaviour were studied. The model was validated through the data obtained from the industry. The developed models have given important contribution to the understanding of how different process parameters affect the drawing process. It also helps in determining the condition of failure. These models can further be used to carry other process improvement studies and analysis.

Jinn Jong Sheu et.al stated that a steel tube drawing process is a forming method to reduce the tube dimensions such as outer and inner diameters and improve the surface quality simultaneously. The profiles of drawing die orifice and the mandrel are key factors to achieve the requirements of tube geometric precision and the surface roughness. The smooth material flow results in a smaller drawing force requirement obviously. While the strain distribution through the direction of tube thickness controls the service quality of tube due to release of the residual stress. In this paper optimum drawing die profile designs were proposed using arc and bezier curves respectively. Design parameters of arc-type and bezier curve-type drawing dies are studied using design of experiment method. Cae simulations were adopted to predict the maximum drawing forces and the mean effective strain deviation along the tube thickness direction. The normalized drawing force and strain deviation were adopted for the cost function calculation. The confirmation test of taguchi method showed the optimum designs are reasonable. The experimental results were carried out and verified the proposed designs are feasible.

G. Mathan et.al explained that starting load during cold drawing process is an important factor affecting draw bench capacity utilization. Finite element simulation was used to optimize die parameters to reduce the high starting load. The shape of the pointed end was optimized to minimize high starting load. Experiments were conducted by modifying the dies of pointers and the resulting drawing force was measured. It was observed that the pointing operation creates out of roundness and due to that a high starting drawing force is required for drawing operation.

Eva Maria Rubio et.al this paper stated that some practical guidelines to select the plug or set of plugs more adequate to carry out drawing processes of thin-walled tubes carried out with fixed conical inner plug are presented. For this purpose, the most relevant input parameters have been considered in this study: the tube material, the most important geometrical parameters of the process (die semi angle, α and cross-sectional area reduction, r) and the friction conditions (Coulomb friction coefficients μ_1 , between the die and the tube outer surface and μ_2 , between the plug and the tube inner surface). The annealed copper UNSC11000, the aluminum UNS A91100, and the stainless steel UNS S34000. The analysis is realized by means of the upper bound method (UBM), modelling

the plastic deformation zone by triangular rigid zones (TRZ), under the validated assumption that the process occurs under plane strain conditions. The obtained results allow establishing for each material, a group of geometrical parameters, friction conditions, a set of plugs that make possible to carry out the process under good conditions and the optimum plug to carry out the process using the minimum amount of energy. The proposed model is validated by means of a now in finite element analysis (FEA) carried out under different conditions and, in addition, by other finite element method (FEM) simulations and real experiments taken from other researchers found in the literature (called literature simulations and literature experimental results, respectively). As a main conclusion, it is possible to affirm that the plug that allows carrying out the process with minimum quantity of energy is cylindrical in most cases.

Praveen Kumar et.al stated that cold drawing is widely used metal forming process with inherent advantages like closer dimensional tolerances, better surface finish and improved mechanical properties as compared to hot forming processes. Due to the ever increasing competition with the advent of globalization it has become highly important to keep on improving the process efficiency in terms of product quality and optimized use of resources. In view of this different models have been proposed and validated using experimental results over a long period of time. The demands in the automobile sector, energy sector and mining sector have led to several modifications in the drawing process. In this paper, process details of cold drawing, major analytical, experimental and numerical studies reported in literature have been reviewed. The review focuses on highlighting the developments associated with the drawing technology that includes improvement in tool design, modification in product geometry, process optimization etc. With the use of Finite element method to achieve the process related objectives.

Zhenhua Wang et.al introduced a system of automatic chain draw bench; achieve a diameter 12 to 102 feeding tube drawing, the drawing system, blanking the full automation of the entire process. Elaborated on the overall design of the system of automatic chain draw bench, Includes functionality to the core of the PLC and inverter control system architecture, hardware and software components and its implementation. The system has been promoted in the relevant enterprises to use, saving labor and equipment to improve the efficiency of the yield of steel, and achieved good results.

S. T. Button et.al defined the numerical simulation of manufacturing processes has become in the last years an important tool to improve these processes reducing lead times and try out and providing products free of defects and with controlled mechanical properties. Finite Element Method (FEM) is one of the most important methods to simulate metal forming. In tube drawing with fixed plug both the outer diameter and the inner diameter of the tube are properly defined if correct process conditions are chosen for the die angle, drawing speed, lubrication and area reduction per pass. These conditions have great influence on drawing loads and residual stresses present in the product. In this work, the cold drawing of tubes with fixed plug was simulated by FEM with the commercial software MSC. Super form to find the best geometry of die and plug to reduce the drawing force. The numerical analysis supplied results for the reactions of the die and plug and the stresses in the tube, the drawing force and the final dimensions of the product. Those results are compared with results obtained from analytic models, and used tooling design. Experimental tests with a laboratory drawing bench were carried out with three different lubricants and two different lubrication conditions.

III. WORKING PRINCIPLE

As on today, cold draw bench is capable of drawing one tube at a time. This causes excess use of human strength, excess power consumption and more wear of machine parts. Also output from machine is less, causing minimized efficiency. In this process, time consumed is much more which minimizes profit. To overcome this problem there is a need to modify dies, plug/mandrel and grippers of machine. We have modify the die with two holes instead of single hole, and existing two mandrel were used to reduce wall thickness of seamless tube. And also two grippers were fitted to drawn trolley.

IV. ACKNOWLEDGMENT

Inspiration and guidance are invaluable in every aspects of life especially in the field of academics, which we have received from our Project Guide **Prof. Prajwal Bansod** and Company Guide **Mr Paliya A.V.** who has shown us right throw in various stages of project. A word of thanks is also placed for our parents for their moral support and last but not the least; we acknowledge a depth of gratitude to all our friends for their constant encouragement and suggestions.

REFERENCES

- [1] Muriel Palengat et.al. "Cold drawing of 316L stainless steel thin-walled tubes: experiments and finite element analysis. Jan.2014"
- [2] Gaurav Kumar Mishra et.al. "Simulation of Seamless Tube Cold Drawing Process using Finite Element Analysis. April 2014"
- [3] Jinn-Jong Sheu et.al. "Optimum die design for single pass steel tube drawing with large strain deformation. 24 October 2014"
- [4] G. Mathan et.al. "On the reduction of high starting load in cold drawing of circular tubes. 12 December 2014"
- [5] Eva Mario Rubio et.al. "Guidelines for Selecting Plugs Used in Thin-Walled Tube Drawing Processes of Metallic Alloys. December 2014"
- [6] Praveen Kumar et.al. "Cold Drawing Process. June 2013"
- [7] Zhenhua Wang et.al. "Automatic Chain Cold Drawing Machine Design. 2016"
- [8] S.T. Button et.al. "Numerical and Experimental Analysis of Tube Drawing With Fixed Plug. December 2005".