

AUTOMATED IRRIGATION SYSTEM USING WIRELESS SENSOR NETWORKS AND GSM MODULE

¹MEKALA NAGAJYOTHI, ²SIRISHA

Department of ECE
Megha Institute of Engineering & Technology For women's
Eduleabad, Ghatkesar mandal, RangaReddy Dist. Telangana, India

ABSTRACT: Agriculture is the source of livelihood of majority Indians and it also has a great impact on economy of the country. In dry areas or in places where there is inadequate rainfall or when a farmer is not aware of how to use water when there is too much of water storage or when there is no water storage irrigation becomes tedious. Wireless sensor networks and their application for precision agriculture is an automated irrigation system used to enhance the use of water for agricultural crops. The system consists of a wireless network that is the soil moisture sensor and temperature sensor placed under the soil where plants roots are reached which is a distributed network. The system has a water level sensor which will indicate the presence of water level in tank. A gateway unit manages the information related to sensors which triggers the actuators, and data is transmitted using GSM module. A software application was developed by predetermining the threshold values of soil moisture, temperature and water level that was programmed into an arm controller. The data from GSM is transmitted /received from/to mobile using software application or normal texting mode which optimizes the use of water quantity.

Keywords: ARM-7- LPC2148 Controller, Embedded C, Flash Magic, GSM, Keil-Compiler.

I. INTRODUCTION

AGRICULTURE is the need of most of the Indians livelihood and it is one of the main sources of livelihood. It also has a major impact on economy of the country. A major quantity of water is used for irrigation system and therefore 85% of available fresh water resources are used for yielding agricultural crops. This resource of water will decrease day by day and consumption of water will dominate and increase more than 85% in upcoming half century. This is due to the high growth in population due to this tremendous growth in population there is huge demand for food. Agriculture is the main source for food production. Using science and technology we need to implement a method by which there can be limited consumption of water.

Till date many methods have come into existence where water can be limitedly consumed. A method where monitoring water status and based on status of water whether it is high or low irrigation is scheduled which is based on canopy temperature of plant, which was captured with thermal imaging. Another method is making use of information on volumetric water content of soil, using dielectric moisture sensors to control actuators and save water, instead of the scheduled irrigation at a particular time of day and supplying water only for a specific duration. This above method just opens the valve and supply water to bedding plants when volumetric content

of soil will drop below threshold value. In this paper a use of the second method where sensors are placed and based on that water is supplied to the field and intimated to the farmer using software application.

Wireless sensor networks is also called as wireless sensors and actor network, are distributed spatially autonomous sensors to monitor physical or environmental conditions as temperature, pressure sound, moisture etc. and it co-operatively passes these data via network to the main location. WSN is built of few to several thousand nodes, where each node is connected to sensors each sensor network node has typically several parts: a radio transceiver with an internal/external antenna, a microcontroller, an electronic circuit for interfacing with sensors and an energy source such as battery. It has many applications such as area monitoring, health care monitoring, environmental sensing, earth sensing, air pollution monitoring, forest fire sensing, landslide detection, water quantity monitoring, natural disaster prevention, music technology.

II. EXISTING SYSTEM

At present there is emerging global water crisis where managing scarcity of water has become a tedious job and there are conflicts between users of water. This is an era where human use and pollution of water resource have crossed the levels which lead to limit food production and low down the ecosystem. The major reason for these limitations is the growth of population which is increasing at a faster rate than the production of food and after a few years this population will sum up to 3-4 billion. Thos growth can be seen in countries which have shortage of water resources and are economically poor. Because of growth in population there is a huge demand to raise food production by 50% in the next half century to maintain the capita, based on an assumption that productivity of existing farm land does not decline. The crop water stress index called as CWSI existed around 30 years ago. This crop water stress index was then integrated using measurements of infrared canopy temperatures, ambient air temperatures, and atmospheric vapor pressure values to determine when to irrigate using drip irrigation. The management of these farms which are in greenhouses will require a data acquisition to be located in each greenhouse and the control room where a control unit is located. These are separated from the production area. At present, the data is transferred using wired communication called field bus. This data is transferred between greenhouses and control room. All the problems related here is presented using CAN and ZigBee protocols.

III. PROPOSED SYSTEM

Here in this paper an experimental scale within rural areas where there is a huge deployment of irrigation system which is implemented using arm controller and wireless communication. The main of this implementation was to demonstrate that the automatic irrigation system can be used to optimize /reduce water usage. It can also be a photovoltaic irrigation system which consists of a wireless network that is the soil moisture sensor and temperature sensor placed under the soil where plants roots are reached which is a distributed network. The system has a water level sensor which will indicate the presence of water level in tank.

A gateway unit manages the information related to sensors which triggers the actuators, and data is transmitted using GSM module. A software application was developed by predetermining the threshold values of soil moisture, temperature and water level that was programmed into an arm controller. The data from GSM is transmitted /received from/to mobile using software application or normal texting mode which optimizes the use of water quantity.

The communication between sensors and data is through the ZigBee protocol. The receiver unit in this system has a duplex communication which is based on cellular internet interface which is done using GSM/GPRS protocol. This is a packet oriented mobile data service which is using 2G and 3G cellular global system for mobile communication.

IV. BLOCK DIAGRAM

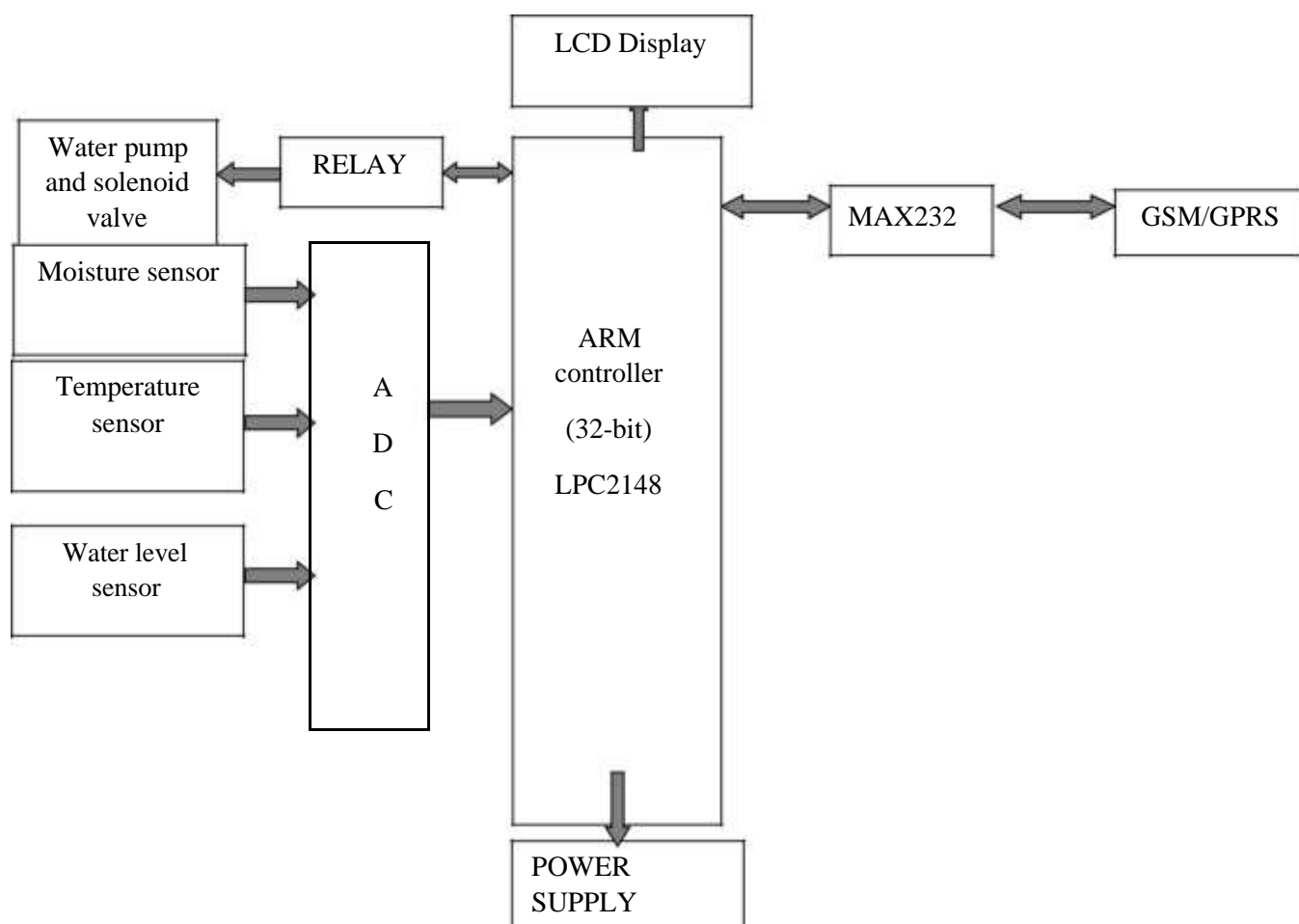

Fig 2.1 Block Diagram

ARM is a family of instruction set architectures for computer processors based on a reduced instruction set computing (RISC) architecture developed by British company ARM Holdings. A RISC based computer design approach means ARM processors require significantly fewer transistors than typical CISC x86 processors in most personal computers. This approach reduces costs, heat and power use. These are desirable traits for light, portable, battery-powered devices including smart phones, laptops, tablet and notepad computers, and other embedded systems. A simpler design facilitates more efficient multi-core CPUs and higher core counts at lower cost, providing improved energy efficiency for servers.

LPC2148 is the widely used IC from ARM-7 family. It is manufactured by Philips and it is pre-loaded with many inbuilt peripherals making it more efficient and a reliable option for the beginners as well as high end application developer.

MAX-232 version of serial I/O standard is most widely used in PCs, GSM/GPS and several devices. In MAX232, high and low bits are represented by following voltage ranges. The MAX232 has 2 sets of line drivers for transferring and receiving data's shown in fig. The line drivers used for TxD are called T1 and T2, while the line drivers RxD are designated as R1 and R2. The MAX232 is an integrated circuit that converts signals from an RS-232 serial port to signals suitable for use in TTL compatible digital logic circuits. The MAX232 is a dual driver/receiver and typically converts the RX, TX, CTS and RTS signals.

The drivers provide RS-232 voltage level outputs (approx. ± 7.5 V) from a single + 5 V supply via on-chip charge pumps and external capacitors. This makes it useful for implementing RS-232 in devices that otherwise do not need any voltages outside the 0 V to + 5 V range, as power supply design does not need to be made more complicated just for driving the RS-232 in this case. The receivers reduce RS-232 inputs (which may be as high as ± 25 V), to standard 5 V TTL levels. These receivers have a typical threshold of 1.3 V, and a typical hysteresis of 0.5 V. The later MAX232A is backwards compatible with the original MAX232 but may operate at higher baud rates and can use smaller external capacitors – 0.1 μ F in place of the 1.0 μ F capacitors used with the original device.

A GSM modem is a specialized type of modem which accepts a SIM card, and operates over a subscription to a mobile operator, just like a mobile phone. From the mobile operator perspective, a GSM modem looks just like a mobile phone. Designed for global market, SIM 300 is a Tri-band GSM/GPRS engine that work on frequency EGSM (Extended GSM) 900 MHZ, DCS(Digital cellular service) 1800 MHZ and PCS (Personal Communication Services) 1900 MHZ . SIM 300 provides GPRS multi-slot class 10 capability and support the GPRS (General Packet Radio Service) coding schemes CS-1, CS-2, CS-3 and CS-4.with a tiny configuration of 40mm x 33mm x 2.85mm, SIM 300 can fit almost all the space requirement in your application, such as smart phone, PDA, phone and other mobile device. The physical interface to the mobile application is made through a 60 pins board-to-board connector, which provides all hardware interface between the module and customer's boards expect the RF antenna interface.

AT commands are instructions used to control a modem. AT is the abbreviation of Attention. Every command line starts with 'AT' or 'at'. That is why modem commands are called AT commands. Many commands that are used to control wired dial up modems, such as ATD(Dial), ATA(answer), ATH(hook control) and ATO(return to online data state), are also supported by GSM/GPRS mobile phones. Besides this common AT commands set GSM/GPRS mobile phones support an AT command set that is specific to the GSM technology, which includes SMS related commands, like AT+CGMS (send message), AT+CMSS (send message from the storage), AT+CMGL (list messages) and AT+CMGR (read messages).Note that the starting "AT" prefix that informs the modem about the start of a command line. It is not the part of the AT command name. For example D is the actual AT command name in ATD and +CMGS is the actual AT command name in AT+CMGS, however some books and websites use them interchangeably as the name of an AT command.

A Liquid Crystal Display (LCD) is a thin, flat display device made up of any number of colors or monochrome pixels arrayed in front of a light source or reflector. It is preferred by engineers because it uses very small amount of electric power. Liquid crystal display (LCD) offers several advantages over traditional cathode ray tube that makes them ideal for several applications. Of course LCD's are flat and they use only a fraction of power required by cathode ray tubes. They are easier to read and more pleasant to work with for long periods of time. There are several tradeoffs as well, such as limited view angle, brightness and contrast, not to maintain

high manufacturing cost. 16x2 LCD is used in this project to display data to user. There are two rows and sixteen columns. It is possible to display 16 characters on each of the 2 rows. It has registers, command and data register.

Float Sensor is an electrical ON/OFF Switch, which operates automatically when liquid level goes up or down with respect to specified level. The Signal thus available from the Float Sensor can be utilized for control of a Motor Pump or an allied electrical element like Solenoid, Lamps, and Relays etc. Float Sensors contain hermetical sealed Reed Switch in the stem and a permanent Magnet in the Float. As the Float rises or falls with the level of liquid the Reed Switch is activated by Magnet in the Float.

You can measure temperature more accurately than a using a thermistor. The sensor circuitry is sealed and not subject to oxidation, etc. The LM35 generates a higher output voltage than thermocouples and may not require that the output voltage be amplified.

This is a water pump and valve where both are in a single component. A pump is driven using a voltage of 12V. This is interfaced to the arm controller indirectly using relay. This relay triggers the 12v voltage and interfaces with arm controller. Then the pump is driven and water is supplied using valve present in that component.

Relay is an electrically operated switch. It is used for voltage conversion from 12V to 5V. It consists of normal open, normal close and common pins on one side and on another side it has ground, enable and 12V where input is given to arm controller and Normal open and common are shorted and given to one end of pump.

Soil moisture sensors measure the water content in soil. A soil moisture probe is made up of multiple soil moisture sensors. This Soil Moisture Sensor can be used to detect the moisture of soil or judge if there is water around the sensor, let the plants in your garden reach out for human help. Insert this module into the soil and then adjust the on-board potentiometer to adjust the sensitivity. The sensor would outputs logic HIGH/LOW when the moisture is higher/lower than the threshold set by the potentiometer. With help of this sensor, it will be realizable to make the plant remind you: Hey, I am thirsty now, please give me some water.

V. WORKING

The working of the system is as follows: ARM microcontroller is interfaced with soil moisture sensor, water level sensor, GSM, LCD, Temperature sensor and water pump. First initialize GSM and wait until it obtains the network. The green light indicates GSM is ON and red light indicates the network strength. Once it obtains complete network there will be delay in blinking of red light. Then initialize LCD, it will display all the statements given in code such as title, and the status of field regarding pump and tank storage.

Using the inputs from soil moisture sensor and water level sensor we turn ON the water pump manually as well as automatically. When the soil is moisturized and soil moisture sensor senses moisture presence it keeps the pump off and when it senses absence of moisture it switches on the pump and supply water to field. Then we need to continuously monitors the sensors and based on that we take some actions. It supplies water until it again sense the presence of moisture, once it senses moisture is present is switches of the pump. Water level sensor gives the presence of water in tank whether it is high or low. Temperature sensor gives room temperature. This whole process is automatic process of irrigation system using wireless sensor networks and GSM module.

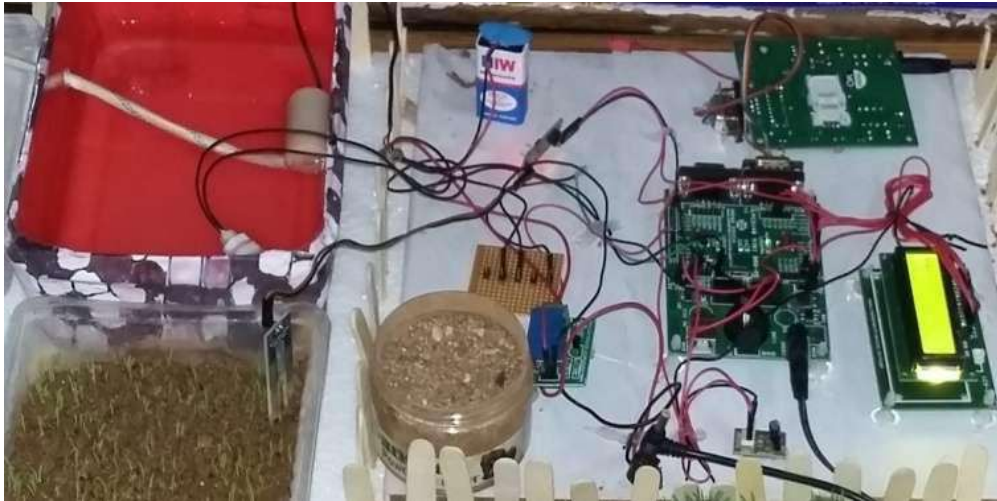

Fig.2 Irrigation System

Now we look at the software application part of the irrigation system which is a manual process.



Fig.3 Software Application

This software application is written using JAVA code which has 2 main options pump on/off and status. This is done using GSM which can be used from any place farmer is. Then he clicks on pump off it sends a message and informs to switch off the pump which will then intimate by sending a SMS that pump is switched off. Then farmer clicks on pump ON here 2 activities take place: If the field is wet and when farmer switches on the pump, it will inform to switch on and intimates by sending a SMS that pump is ON but it senses that field is wet and switches the pump off and intimates pump off by sending SMS. If the field is wet and when farmer clicks on switch ON pump it will inform to switch ON pump and intimates by sending a SMS that pump is on. If farmer wants to know the status of field whether the soil is dry or wet and tank storage is low or high, farmer can get to know these details by clicking on status. Farmer will receive a message as tank is empty/full and water storage is high/low. There is another method controlling field: If a farmer is not having an android mobile and farmer has no software application, a farmer can use normal mobile by sending normal text messages as follows:

- \$1- indicates pump ON.
- \$2- indicates pump off.
- \$3- indicates status.

ALGORITHM

1.) INITILAISE GSM:

```
unsigned char cmd_1[]="AT" //attention command
```

```

unsigned char cmd_2[]="ATE0"; //charecters not echoed
unsigned char cmd_3[]="AT+CNMI=2,1,0,0,0"; //procedure for message reception from the n/w
unsigned char cmd_4[]="AT+CMGF=1"; //set text mode
unsigned char cmd_6[]="AT&W"; //modification saving in eeprom

```

2.) UART INITIALISE:

```

PINSEL0|=0X00000005;
U0LCR=0X83;
U0DLL=0X61;
U0DLM=0X00;
U0LCR=0X03

```

3.) ARM:

```

PINSEL1|=0X15400000;
ADCR =0X00200404; // FRM MSB- SCBITS=1,OPNL MODE, 8BITMOD,CLK FREQ,4th CHANNEL
ADCR|=0X01000000;
while(!(ADDR & 0X80000000)); //WHEN DONE BIT IS NOT HIGH BE HERE val=ADDR;
val>>=6;
val&=0x000003ff;
val=val/5;
return(val);

```

4.) IODIR1 = 0X00200000; // FOR WATER PUMP

```

IODIR0 &=0x00100000; //// for water float
if(water_float1==0X00100000) //// for water float
IODIR0 &= 0x00000400; ////for moisture if(moisture==0X00000000) ////p0.10 for moisture

```



Fig 4 Android Application

The simulation part is as follows:

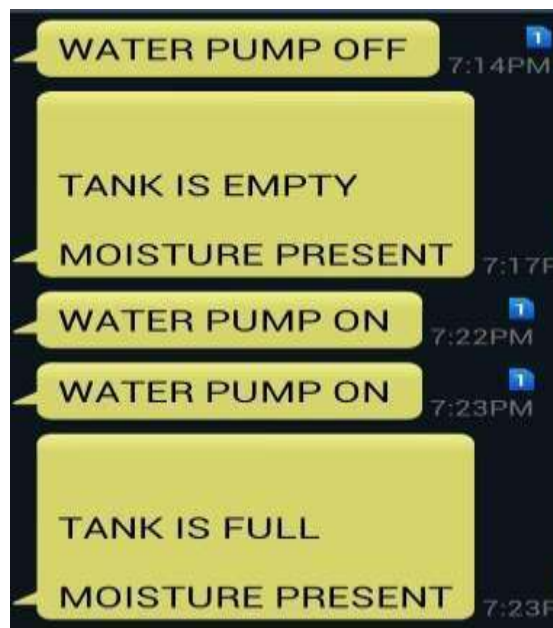

Fig 5 Simulation User Receives Messages

VI. ADVANTAGES

The system is very economical in terms of hardware component and power consumption. The system helps in saving of water and electricity. It can be implemented in large agricultural areas. With the help of GSM user can control the motor from anywhere by just sending SMS. The system helps in labor problem when there are no labors to work and eliminates man power. System can be switched into manual mode whenever required. It is useful to all climatic conditions and all types of irrigation.

VII. APPLICATIONS

Irrigation can be done in fields, gardens, farms etc. It is efficient for varieties of crops. This implementation can be used for patient monitoring. The software application developed for this system can be used for household works such as tank storage. This system can be operated automatically as well as manually.

VIII. FUTURE SCOPE

Rain gun sensor can be added so that when it rains there won't be floods and this shield the field and avoids floods. Rain water harvesting can be done and this harvested water can be used to irrigate fields. Hooters can be used so that it gives siren at various occasions such as intrusion detection, floods etc. Using IR sensors any object passing into fields can be detected and alerted.

IX. CONCLUSION

The automated irrigation system implemented is very feasible and cost effective. The system is very economical in terms of hardware component and power consumption. The system helps in saving of water and electricity. It can be implemented in large agricultural areas. With the help of GSM user can control the motor from anywhere

by just sending SMS. The system helps in labor problem when there are no labors to work and eliminates man power. System can be switched into manual mode whenever required. It is very useful in all climatic conditions and all types of irrigation. In this solar power can be made use of where cost of electric power would be expensive. It can be implemented for variety of crops.

X. ACKNOWLEDGEMENT

The successful completion of project would be incomplete without complementing those who made it possible and whose guidance and encouragement made our efforts successful. With deep sense of gratitude we acknowledge the help and encouragement of our project guide, Assoc. Prof. **Mrs Sujatha S.**, CMRIT Bangalore, for her successful guidance, support, help and suggestions. We are thankful to our Head of Department, Mrs Sharmila K.P. and Senior Professor Dr. K. V. S. Ananda Babu, CMRIT for their support and enquiry towards our project. We also take this opportunity to extend our regards to Dr. Sanjay Chitnis Principal, CMRIT for his support. We would also like to thanks all those who were involved directly or indirectly and who helped in our project. Finally, we would like to thanks our parents and friends who have bestowed faith in our ability and have helped us stand in a place where we are.

REFERENCES

- [1] Veena Divyak ,Ayush Akhouri,A Real time implementation of a GSM based Automated Irrigation Control System using drip Irrigation Methology (Volume 4, Issue 5,May 2013)
- [2] Mansour ,H.A, You sifEl-Melhem ,impact tthe automatic control of closed circuits raingun irrigation system on yellow corn growth and yield(International Journal of Advanced Research (2013), Volume 1, Issue 10, 33-42)
- [3] m. guerbaoui, y. el afou, a. ed-dahhak, a. lachhabpc-based automated drip irrigation system(Vol. 5 No.01 January 2013)
- [4] Purnima, S.R.N Reddy, —Design of Remote Monitoring and Control System with Automatic Irrigation System using GSM Bluetoothl, on IJCA,2012
- [5] Cottet F. (2001): LabVIEW: programmation et applications. Dunod, pp. 415.
- [6] Eddahhak, A.; Lachhab, A.; Ezzine, L.; Bouchikhi, B. (2007): Performance evaluation of a developing greenhouse climate control with a computer system. AMSE Journal Modelling C, 68 (1), pp. 53-64.
- [7] Elattir H. (2005): La conduite et le pilotage de l'irrigation goutte-à-goutte en maraîchage. Bulletin mensuel d'information de liaison du programme national de transfert de technologie en agriculture (PNTTA), pp. 124
- [8] Gonzalez, R .A.; Struve, D.K.; Brown L.C. (1992): A computer controlled raingun irrigation system for container plant production Hort Technology, 2(3), pp. 402-407.
- [9] Howell, T.A. (2001): Enhancing water use efficiency in irrigated agriculture. Agron. J, 93, pp. 281-289.
- [10] AbouKheira A. A. (2009). Comparison among different irrigation systems for deficit- irrigated transgenic and non transgenic yellow corn in the Nile Valley. Agricultural Engineering International: the CIGR Ejournal. Manuscript LW 08 010. Vol. XI:1 25.
- [11] "Philosophy and Goals". Android Open Source Project.Google. Retrieved 2012-04-21.
- [12] P. Varady, Z. Benyo, and B. Benyo, —An open architecture patient monitoring system using standard technologies, IEEE Trans. Inf. Technol. Biomed., vol. 6, no. 1, pp. 95–98, Mar. 2002.
- [13] J. Bai et al., —The design and preliminary evaluation of a home electrocardiography and blood pressure monitoring network, J. Telmed. Telecare, vol. 2, no. 2, pp. 100-06, 1996.

- [14] G. Williams, P. J. King, A. M. Capper, and K. Doughty, —The electronic doctor (TED)—A home telecare system,|| in Proc. 18th IEEE Annu. EMBS Int. Conf., Amsterdam, The Netherlands, Oct. 31-ov. 3, 1996, vol. 1, pp. 53-4.
- [15] P. Johnson and D. C. Andrews, —Remote continuous physiological monitoring in the home,”
- [16] J. Telmed. Telecare, vol. 2, no. 2, pp. 107-13, 1996. K. Doughty, K. Cameron, and P. Garner, —Three generations of telecare of elderly,|| J. Telmed. Telecare, vol. 2, no. 2, pp. 71-0, 1996.
- [17] T. Fukatsu and M. Hirafuji, —Field monitoring using sensor-nodes with a web server,|| J. of Robotics and Mechatronics, vol. 17, no. 2, pp. 164-172, 2005.
- [18] K. Langendoen, A. Baggio, and O.Visser,||Murphy loves potatoes: experiences from a pilot sensor network deployment in precision agriculture,|| The 20th Int. Parallel and Distributed Processing Symposium, pp. 25-29, April 2006.
- [19] N. Wang, N. Zhang, M. Wang, —Wireless sensors in agriculture and food industry—recent development and future perspective,|| Comp. Electron. Agric. vol. 50, no. 1, pp. 1-14 2006.
- [20] T. Fukatsu and M. Hirafuji, —Field monitoring using sensor-nodes with a web server,|| J. of Robotics and Mechatronics, vol. 17, no. 2, pp. 164-172, 2005.
- [21] Sunnorth, SPCE061A compiler user menu v1.0, www.sunnorth.com.cn. Spectrum Technologies Inc., External temperature sensor category #3667.
- [22] E. P. Eldredge, C. C. Shock, and T. D. Stieber, —Calibration of granular matrix sensors for irrigation management,|| Agronomy Journal, vol. 85, pp.1228-1232, 1993.
- [23] S. J. Thomson, T. Youmos, and K. Wood, —Evaluation of calibration equations and application methods for the Watermark granular matrix soil moisture sensor,|| Appl. Eng. Agric., vol. 12, pp. 99-103, 1996.
- [24] Electronique-Diffusion Company Inc., REHS135, www.elec dif.com.
- [25] Allguy International Co., Ltd., CDS photoconductive cells, http://cn.commerce.com.tw/modules.php?modules=company&action=company_inside&ID=A0001712&s=h. Ready International Inc., ZigBee 3160 module, <http://www.rיתי.com/ch/>
- [26] M. Yu, H. Mokhtar, and M. Merabti, —A survey on Management in wireless sensor networks,|| www.cms.livjm.ac.uk/pgnet2007/Proceedings/Papers /2007-099.pdf. www.intechopen.com
- [27] Wireless Sensor Networks and Their Applications to the Healthcare and Precision Agriculture 21 Sapon Tanachaiwiwat, Pinalkumar Dave, Rohan Bhindwale, Ahmed Helmy, —Secure locations: routing on trust and isolating compromised sensors in location-aware sensor networks,|| SenSys'03, pp. 324-325, LA, CA, USA, Nov. 5–7, 2003.
- [28] S Harte, A Rahman, K M Razeeb, —Fault tolerance in sensor networks using self-diagnosing sensor Node,|| The IEE Int. Workshop on Intelligent Environments, pp. 7-12, 2005.
- [29] D. Estrin, R. Govindan, J. S. Heidemann, S. Kumar, —Next century challenges: scalable coordination in sensor networks,|| In Mobile Computing and Networking, pp. 263-270, 1999.
- [30] A. T. Tai, K. S. Tso, W. H. Sanders. —Cluster-based failure detection service for large-scale ad hoc wireless network applications in dependable systems and networks,||
- [31] Proceedings of the 2004 Int. Conf. on Dependable Systems and Networks, DSN ' 04. 2004.
- [32] T. Clouqueur, K. Saluja, P. Ramanathan, —Fault tolerance in collaborative sensor networks for target detection,|| IEEE Transactions on Computers, vol. 53, pp. 320-333, 2004.
- [33] M. Ding, D. Chen, K. Xing, X. Cheng. —Localized fault- tolerant event boundary detection in sensor networks,|| in Proceedings of INFOCOM, 2005.
- [34] J. Chen, S. Kher, and A. Somani, —Distributed fault detection of wireless sensor networks,|| DIWANS'06, Los Angeles, USA:ACM Pres, pp. 65-72, 2006.