

ARDUINO BASED GREETING CONTROLLED ROBOT

¹Patil Tushar R, ²Goad Prashant M., ³Patil Jagdish B, ⁴Bari Jayesh P

^{1,3,4}Students, ²Professor

Abstract: This paper introduces a service robot which performs the repetitive task of welcoming people graciously both by a sweet recorded message and hand gesture representing “Namaste” – an Indian traditional method wishing of people. Most commonly we observe people dressed in the imitation costumes of Mickey Mouse, Donald duck, Teddy bear etc., near schools, colleges, offices, in parties and marriages etc. Here the people wear only costume and performs the task of wishing unfamiliar people mechanically which is really a mind-numbing task. In this paper we designed a service robot that acts as a host in receiving people and performs the same task for hours without getting weary. This is a low cost flexible robot which can be designed and constructed without difficulty.

IndexTerms: Robots, Namaste Ping Sensor, Arduino, servos, Relays, position of robot

I.INTRODUCTION

A robot is a machine, usually an electromechanical machine that is processed by a computer program or electronic circuitry. Robots have replaced humans in the assistance of performing those repetitive and dangerous tasks which humans prefer not to do, or are unable to do due to size limitations, or humans could not survive in the extreme environments. Modern robots are classified into different categories such as mobile robots, Commercial or industrial robots, service robots based on their performance features. This is a service robot that which performs the repetitive task of welcoming people both by recorded voice message and by hand movement representing “Namaste” in its vicinity. Usually when we invite people to home, office, marriage functions or parties etc., we need to assign a person to receive them and greet at the entrance. If this greeting is to a limited amount of people then the task appears simpler. But if it is to greet hundreds or thousands of people, then the task appears amalgam and lackluster because the person has to wait for hours and repeat the same process of wishing with affection and enthusiasm carrying a broad smile. Hence we tried to simplify the complexity by developing a robot which could stand at the doorway and wish each and every person within its vicinity. The idea of a robot greeting them in an Indian traditional style, along with a hand gesture “NAMASKAR” appeals to people. The style can be changed by making minimum changes in the program. Moreover robot doesn't get tired or bored and hence can perform its duty for longer hours. Children attending the

Function also will be more eager and excited at such reception. We present our exploration of the emotional impact that abstract mechanical or robot motion has on Human-Robot-Interaction (HRI). We emphasis for the importance of designing for robot action at the time of work. We discuss our design approach and motion planning as a process of detailing a task into discrete motions. We implement different way of robot motion by human order. We believe that our findings can inform and provide important insight into the purposeful use of motion as a design tool in social human-robot interaction.

BLOCK DIAGRAM OF ROBOT

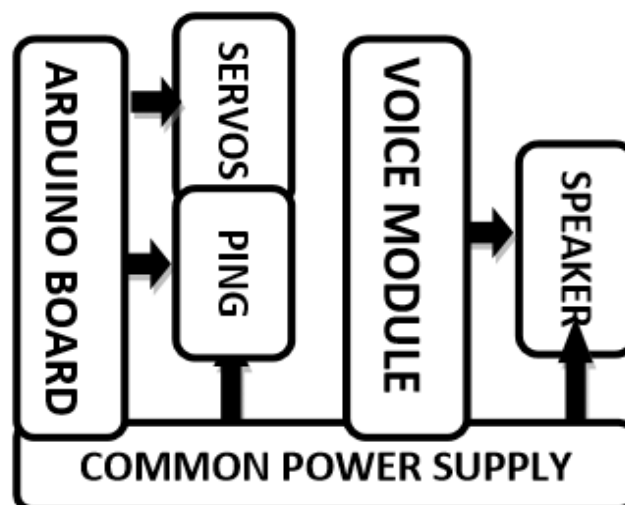

FIG 1: Block diagram of Namaste Robot with voice.

Fig 1 represents the block diagram of the robot with voice commands programmed. Module and development board are connected to the common power supply as shown in the above block diagram. The description of each block is as follows:

Power Source: A common power supply provides to all the required modules. The modules require an operating voltage of 5-volts and current in milliamps

- **Sensor**

The ping sensor is an ultrasonic sensor which uses SONAR to determine the distance of an object in its vicinity. This sensor is used as eyes to the robot to detect an obstacle

- **Voice Playback IC**

This voice playback IC provides the prerecorded message that plays at predefined frequency rate. The playback is transferred to the audio amplification unit

- **Relay**

A relay is an electrically operated switch. Current flowing through the coil of the relay creates a magnetic field which attracts a lever and changes the switch contacts

- **Microcontroller**

A microcontroller is a single integrated chip that contains the processor and non-volatile memory internally present in it

II.MICROCONTROLLER BASED ON ARDUINO

- **Arduino**

Arduino is a tool for making computers that can sense and control more of the physical world than desktop computer. It is an open-source physical computing platform based on a simple microcontroller board. There are many other microcontrollers and microcontroller platforms available for physical com

TWO VITAL FEATURES OF THE ARDUINO ARE:

- **Inexpensive**

Arduino boards are relatively inexpensive compared to other microcontroller platforms

- **Open source and extensible software**

The Arduino software is published as open source tools. The language can be expanded through C++ libraries, and people wanting to understand the technical details can make the leap from Arduino to the AVR C programming language on which it's based.

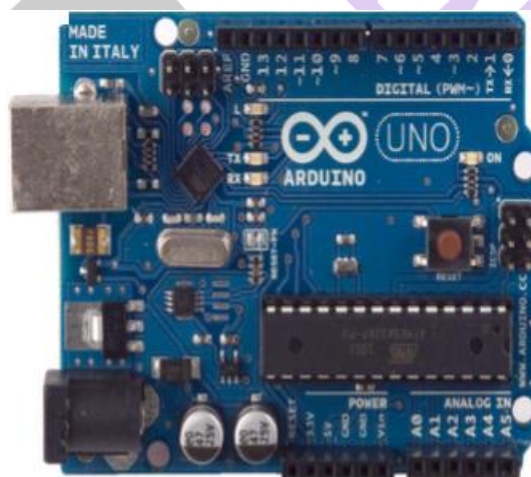

FIG B : Arduino board

Technical Specifications of Arduino board

- Microcontroller - ATmega328.
- Operating voltage - 5V.
- Maximum input voltage - 7-12V.
- Digital I/O Pins 14
- Analog Input Pins 6.
- DC Current per I/O Pin - 40 mA.
- DC Current for 3.3V Pin - 50 mA.
- Flash Memory - 32 KB

2.2 ARDUINO CODE DEFINITIONS

- **Setup()**

A function present in every Arduino sketch. Run once before the loop () function. If is often used to set pin mode to input or output. The setup () function looks like: void setup () { //code goes here }

- **Loop()**

A function present in every single Arduino sketch. This code happens over and over again. The loop () is where (almost) everything happens. The one exception to this is setup () and variable declaration

- **void loop()**

```
{ //code goes here }
```

- **Input**

A pin mode that intakes information

- **Output**

A pin mode that sends information

- **HIGH**

Electrical signal present (5V Uno). Also ON

- **LOW**

No electrical signal present (0V). Also OFF or False in Boolean logic

- **Digital Write**

Assign a HIGH or LOW value to a pin already declared as an output

- **PWM**

PWM stands for Pulse-Width Modulation, a method of emulating an analog signal through a digital pin having value from 0 and 255. Used with analog Write

III. INTERFACING THE PING SENSOR WITH ARDUINO

3.1 Working of a Ping Sensor

Figure C represents the working principle of a ping sensor. The HC-SR04 ultrasonic sensor uses sonar to determine distance to an object. It offers excellent range accuracy and stable readings in an easy-to-use package. Its operation is not affected by sunlight or black material like Sharp rangefinders are (although acoustically soft materials like cloth can be difficult to detect). A ping sensor uses high frequency sound to accurately measure distance. This high frequency sound signal is supplied through an IO trigger for at least 5µs sequence of high level signal. The module sends eight 40 kHz square waves and in return detects if it is receiving any pulse signal i.e., the echo signal. If the signal is back through high level, time of high output IO duration is the time from sending ultrasonic to returning. Test distance = (high level time velocity of sound/2 = (340M/S)/2).

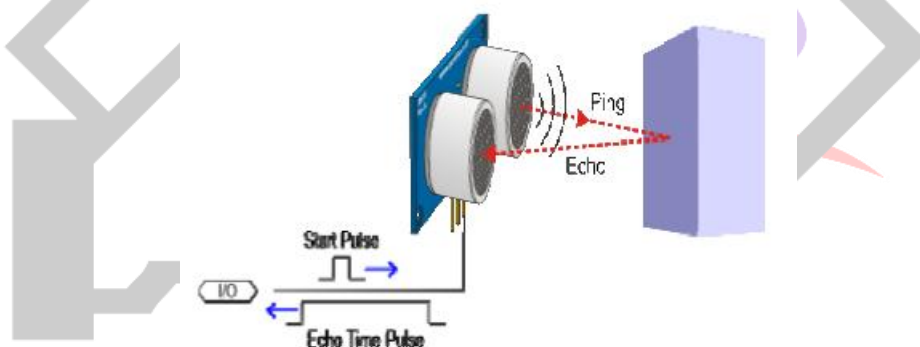

FIG C : Working Principle of Ping Sensor

3.2 Specifications for ping sensor

- Working voltage - 5V(DC)
- Current - 15mA
- Sensor angle - Not more than 15 Degrees.
- Detection distance - 2cm-450cm.

3.3 Pin connections from HC-SR04 Ping sensor to Arduino

For interfacing the ping sensor to the Arduino board there are 4 pins present in the Arduino board they are VCC, GROUND, TRIGGER , ECHO The pins 12 & 13 are the I/O pins that are present on the Arduino Uno board i.e. (D-0 D-1)

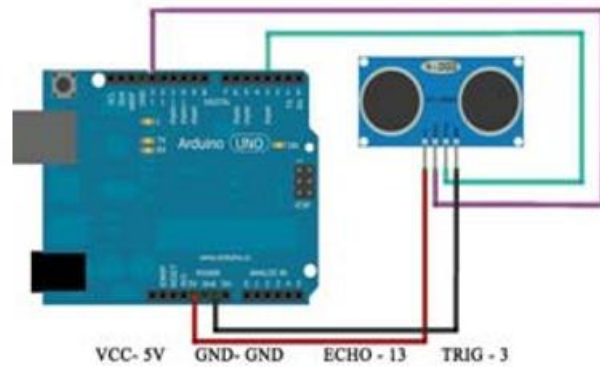

FIG D : Connections from Ping Sensor To Arduino Board

IV.INTERFACING THE SERVOS WITH AURDINO

Servo motors are dc motors with a servo mechanism that lets us control the precise position of the Shaft. A servo mechanism is an error correction mechanism that senses the negative error and applies a correction accordingly. There are many types of Servo Motors available depending upon type of application. They are used in areas requiring position control. In this paper we used RC Servo Motors or the type of Servo motors used in Robotics / Radio Control Projects. A Servo motor constitutes of 4 parts - a DC motor, a Gear system, A Potentiometer (for sensing feedback) and a Control Circuit. Here the Control Circuit and the Potentiometer together form the Servo Mechanism as shown in figure E

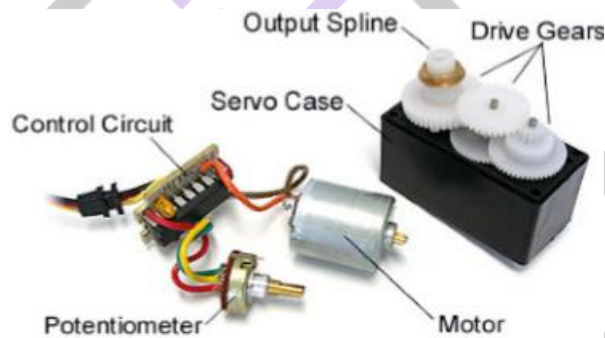

FIG E : Parts of a Servo Motor

4.1 Working of servo motor

The Control Circuitry on the Servo motor drives the DC motor based on input signals it receives. The output shaft of the DC motor is connected to the gear assembly. The gear assembly moves the potentiometer when it rotates. The Control Circuitry gets feedback from this potentiometer and spins the DC motor to obtain a desired angle between 0° & 180°. The range of movement of the potentiometer is mechanically restrained

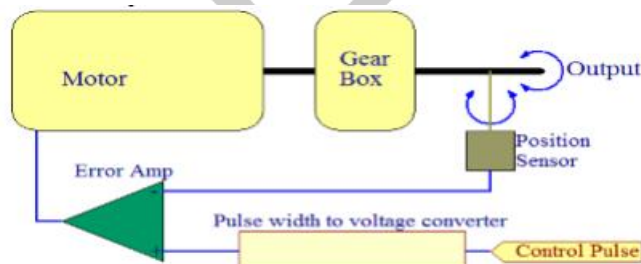

FIG 6: Internal working of a servo motor.

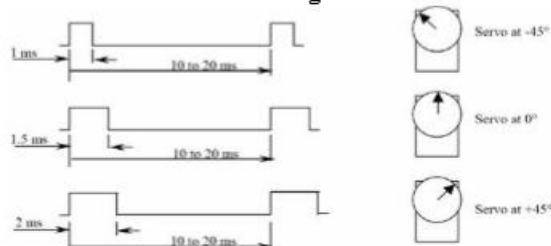

FIG F : Square pulses of the servo motor

4.2 Controlling Servo Motors

To Control a servo we need to apply a pulse once every 20 milliseconds. The duration of this pulse will determine the Servo Angle. For most Servo's a Pulse duration of 1ms will set the shaft position to 0° and a pulse duration of 2 milliseconds will set the shaft position to 180°

4.3 Controlling Servos with an Arduino

Arduino provides us with a servo control library that lets us control servos with ease. The library provides us with an option of writing both microsecond's value and angle values. In this paper we used five servos to control the movements of the robot i.e., head, right shoulder, right elbow, left shoulder and left elbow. Here the digital I/O pins D5, D6, D9, D10, D11 pins represents in the Arduino board connected to servos

SERVO	PIN	LOCATION
Servo 1	D6	Head rotation
Servo 2	D5	Left elbow
Servo 3	D11	Right elbow
Servo 4	D9	Left shoulder
Servo 5	D10	Right shoulder

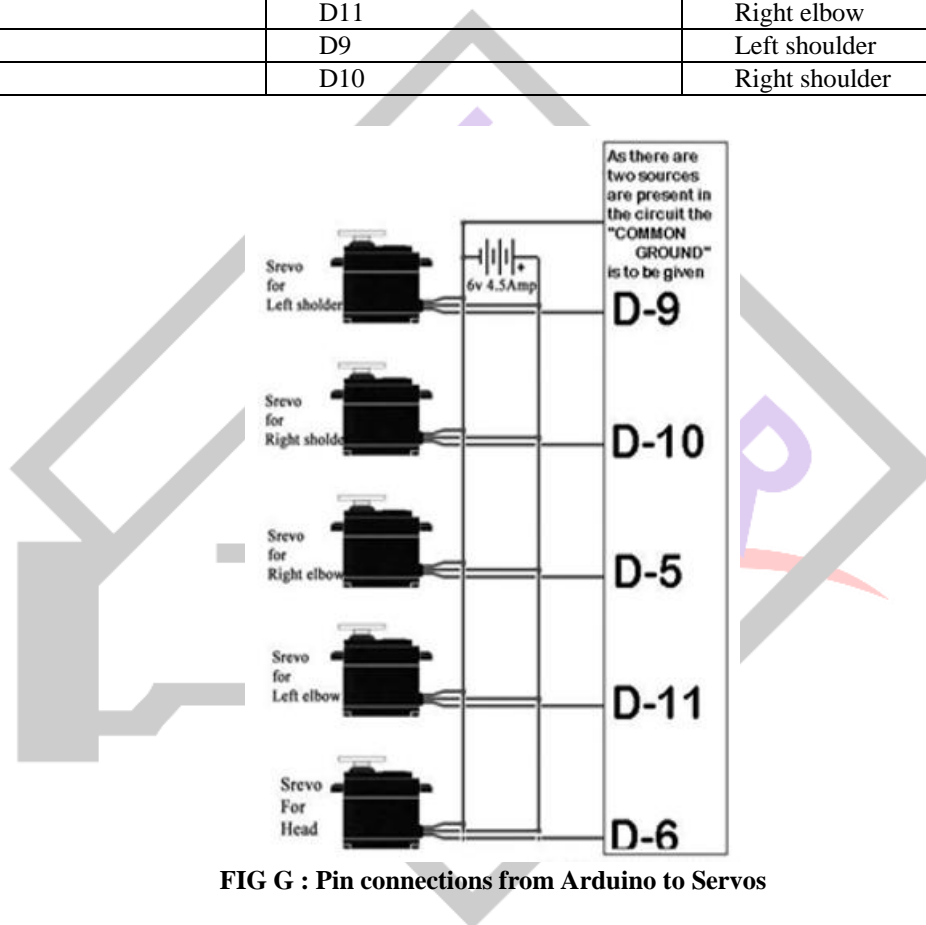

FIG G : Pin connections from Arduino to Servos

V.SIMULATION SCENARIO

In this section the working of the robot is represented in a step wise manner along with the simulated results. Figure H shows that the robot is in initial state. I.e. the servos 2,3,4,5 of the robot are in '0°' state or OFF state. The Servo1 is turned ON for 50ms and operated in HIGH state. The head of the robot rotates from center to left and then to right and back to center due to rotation of Servo1 from 0° to 180°. The movement of the head indicates that the robot is searching for an obstacle. When any obstacle is sensed by the Ping sensor which acts like eyes of robot, the head position returns to the center and Servo1 remains at 90° angle and turns OFF and is operated in LOW state as shown in Figure H

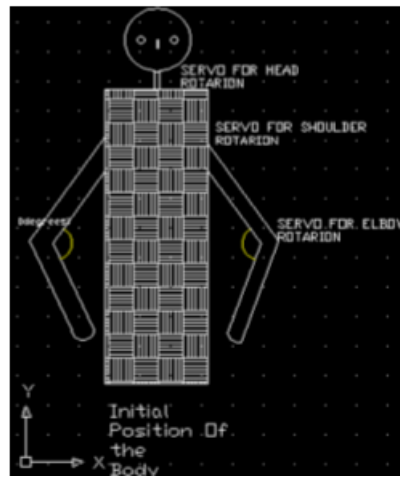

FIG H : Initial position of the ROBOT

Once the Servo 1 turns OFF, the Servos 4 & 5 turns ON and switches to HIGH state i.e. the signal line is activated for the left and right shoulders of the robot. Now the hands of robot can make movement upwards. The shoulder servos are connected to the Arduino Digital I/O pins (D9, D10). For these pins the signal line is high and the position of the servo is changed by an angle of 90° as shown in the Figure 13. Now the Servos 4 & 5 turns OFF.

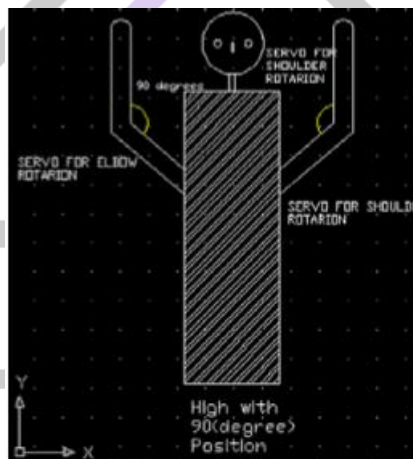

FIG I : 2nd Position of the Robot

Once the Servos 4 & 5 turn OFF, the signal line of Servos 2 &3 turns ON and provides movement of elbows to the robot. In order to move the elbow gracefully a time delay of 15μ is provided for both the servos. If there is no time delay then the movement will be very fast and will appear ON an odd manner

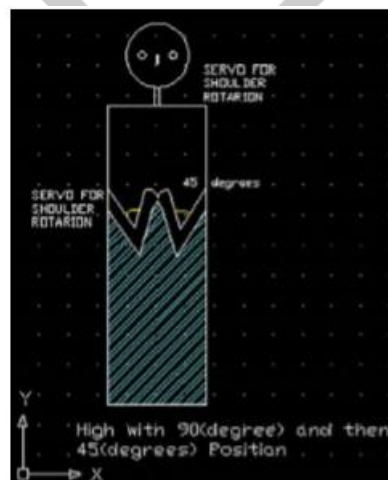

FIG J : 3rd position of the ROBOT

This robot now represent the Namaste position after the 90° of high motion from the shoulders then the action of 45° from elbow movement. Here in the Namaste position there is a delay of '3' seconds is applied in that position. The digital pins that are used for the movement are (D5, D11, D9, D10) are at low state. At all these cases the position of the head is in 90° and basically in the OFF state. All these actions depend upon the signal line that comes from the Arduino Uno board. Again the 4th position is

matched with the 2nd position that is after the 3 seconds of delay from the Namaste position it is back to the 2nd position as observed. The 45 degree of operation is performed.

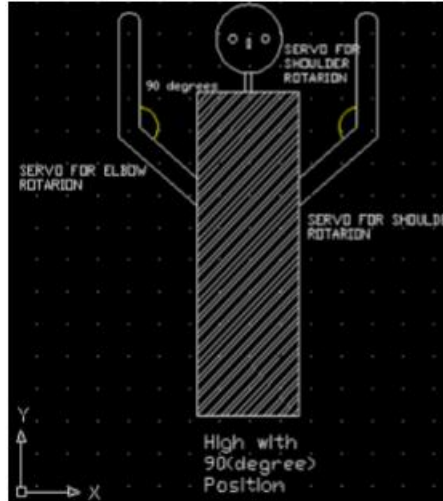

FIG K : 4rd position of the ROBOT

This is the final view that is observed all the servo lines are set to zero (D5,D11,D10,D9) are down to OFF state. And the 'D6' digital pin is HIGH that which is used for the head rotation is performed and the PING again starts searching for the obstacle panning from left to right

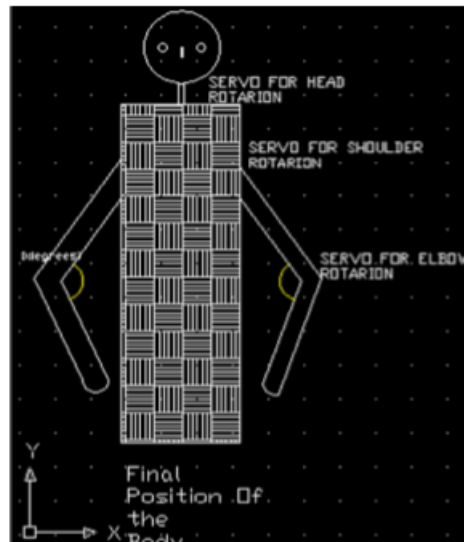

FIG L: 5th position of the ROBOT

VI.CONCLUSION

The main aim of this paper was to construct a "Namaste robot" which provides the service of welcoming people graciously. We have constructed a model robot which can sense people walking before it within its vicinity and welcome them courteously. Different messages can be saved according to the requirement of the customer. This is a low cost service robot which can be designed and used in public places, functions, parties ETC which attracts a lot of attention from kids

References

- [1] A STUDY ON REAL-TIME CONTROL OF MOBILE ROBOT WITH BASED ON VOICE COMMAND, BYOUNG-KYUN SHIM ; YOO-KI CHO ; JONG-BAEM WON;SUNG-HYUNHAN CONTROL, AUTOMATION AND SYSTEMS (ICCAS), 2011 11TH INTERNATIONAL CONFERENCE ON PUBLICATION YEAR: 2011
- [2] SPEECH RECOGNITION AND ITS APPLICATION IN VOICEBASED ROBOT CONTROL SYSTEM, LUO ZHIZENG; ZHAOJINGBING INTELLIGENT MECHATRONICS AND AUTOMATION, 2004. PROCEEDINGS. 2004 INTERNATIONAL CONFERENCE
- [3] A STUDY ON PRECISE CONTROL OF AUTONOMOUS DRIVING ROBOT BY VOICE RECOGNITION, SUNG-WON JUNG ; KI-WON SUNG ; MOON-YOUL PARK ; EON-UCK KANG ; WON-JUN HWANG ; JONG-DAE WON; WOO-SONG LEE ; SUNG-HYUN HAN ROBOTICS (ISR), 2013 44 TH INTERNATIONAL, SYMPOSIUM ON DOI:10.1109/ISR.2013.6695640 PUBLICATION YEAR: 2013
- [4] A MECHANISM FOR HUMAN - ROBOT INTERACTION THROUGH INFORMAL VOICE COMMANDS, D'MELLO, S.; LEE McCAULEY, ; MARKHAM, JAMES ROBOT AND HUMAN INTERACTIVE COMMUNICATION, 2005. ROMAN 2005. IEEE INTERNATIONAL WORKSHOP, DOI:10.1109/ROMAN.2005.1513777, PUBLICATION YEAR: 2005