

SMART HELMET– A Review Paper

¹Prof. M. V. Korade, ²Megha Gupta, ³Arefa Shaikh, ⁴Snehal Jare, ⁵Yashi Thakur

¹Assistant Professor, ^{2,3,4,5}UG Students
Computer Engineering Department,
Sandip Institute of Engineering & Management

Abstract: The main cause of death in two-wheeler drivers is over-speeding, drunken driving and careless driving. Numerous lives could have been saved if emergency medical service could get accident information and reach in time to the scene. To resolve these current issues we are developing a helmet which gives best solution. These main issues motivates us for developing this project. The objective of our project is to design a low-cost intelligent helmet that is capable of identifying alcohol consumption and preventing road accidents. The main purpose of this smart helmet to provide safety for rider. This is implemented by using advance features like alcohol detection, accident identification, location tracking, used as a hands-free device, solar powered, fall detection. In our project, its compulsory to wear helmet, without helmet ignition switch cannot ON. If rider is drunk or if accident takes place, then automatically ignition switch is locked, and a message will be send automatically to their registered number with their current location. It provides a feature to receive a call while driving by using Bluetooth.

Keywords: Smart Helmet, IoT, GSM, GPS, Sensors, Accidents Prevention, Alcohol, Message, Bikers.

Introduction: In today's fast paced life most of accidents happen due to drinking and driving. Most of the countries are forcing the motorists to wear a helmet, however rules are being violated by uncivilized citizens. Thus the objective of this project is to make sure people wear helmets and then ride bikes. Another objective is to make sure the rider isnt drunk. The rider won't be able to ride the bike if he is drunk. One more objective is to reduce the fatality of the accidents by sending a message to the riders relative about the accident. . This is implemented by using advance features like alcohol detection, accident identification, location tracking, and use as a hands free device, solar powered. Its compulsory to wear helmet, without helmet ignition switch cannot ON.

Literature Survey:

According to the recent Research paper in 2016 titled '2 Helmet using GSM and GPS technology for accident detection and reporting system', The author specially developed this project to improve the safety of the bikers. The objective of this project is to study and understand the concept of RF transmitter and RF receiver circuit. The project uses ARM7, GSM and GPS module. The project also uses buzzer for indication purpose. Whenever the accident will occur then accident spot will be note down and information will send out on the registered mobile number. [2] The major disadvantage of this project is they are not using any display device for showing the current status. Also the cost of helmet is still high since helmet is designed for only one purpose.

According to the Research paper in 2015 titled 'Microcontroller based smart wear for driver safety', In this paper author has discussed on the speed of the vehicle. In this application the project will be monitoring the areas in which the vehicle will be passing. On entering any cautionary areas like schools, hospitals, etc the speed of the vehicle will be controlled to a predefined limit. LCD is used for showing the various types of messages after wearing the helmet. The author has worked only on the phenomenon of accident which is generally happens due to drunk and drive. But as we know that the accident in the area is not happens only due to consuming alcohol but also other parameters like speed are also responsible.

According to the Research paper in 2016 titled 'Smart Helmet', In this paper the main objective of author is to force the rider to wear the helmet. In this competitive world one of the survey says that the death trolls due to motor bike accidents are increasing day by day out of which most of these casualties occurs because of the absence of helmet. Traffic police cannot cover remote roads of city. Thats why over primary objective is to make the usage of the helmet for two wheelers "compulsory ". Thus ,no one other than the owner himself ,who doesn't have "password" which would have been created by the owner, can use the bike. In this author has proposed the feature that the bike will not start unless the bike rider does not wear the helmet .The other this module basically deals with the checksum of rider if he is wearing the helmet or not on first place to achieve this ultrasonic sensor is been used .based on this the signal are been sent to the next module voice recognition module use for authentication purpose. Arduino is also used in this project which is an open source tool for making computer that can sense.

According to the Research paper in 2015 titled 'Smart Helmet', In this project the author has proposed the smart helmet because of growing bike accident. People get injured or might be dead because of not wearing helmet. Continuously no one follows road rules .So to overcome these problem this helmet is been designed. The middle class families prefer to buy motor bike over four wheelers, because of the low prices, various variety available in the market. Author has also used encoder IC that receives parallel data in the form of address bits and control bits the other author has used smart system for helmet. But in this project author have not focused on the major issue that will occur in future regarding the alcohol and many other.

Limitations and challenges in Existing Systems:

1. Bikers do not wear helmets in the region where traffic checking is not done.
2. There is a tendency of the driver to wear helmet only where the anticipate checking may takes place, they do not wear helmet where no checking is done.
3. The vehicle may be turn on or may be stolen by passing the ignition switch.
4. Testing alcohol content present in blood in each individual rider in big countries like India is almost impossible.
5. Accidents due phone calls as previous helmets do not contain Bluetooth speakers.

System Architecture:

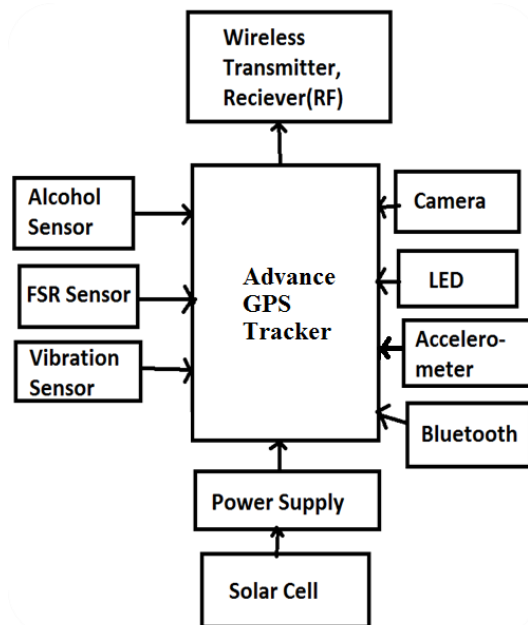

Scope of Improvement:

Any system always has a scope for improvements and more advancement. All the systems studied under the literature survey have their own different features. All the systems proposed till date are used only for sending message in case of accident. There could be such a system where only alcohol detection is present. Here in this system many advanced features are added and also the previous features are clubbed in a single system. It will send message automatically when rider met an accident with helmet on. RF transmitter and receiver are used for starting the two wheeler, if rider not wearing the helmet the bike will not get start. The alcohol sensor will sense the alcohol and it will lock the ignition if drunk. The solar sense is generating power for the system. It can tracked easily with location when bike is stolen. It can also use to receive call while driving through wireless Bluetooth Speakers.

Conclusion:

Thus this system is very effective for the safety purpose of the user. User has to wear helmet to ride a bike and hence traffic rules will be followed by the rider. This system is under pocket control i.e. Riding the two wheeler vehicle having safety in hand and in budget. This system has easy functionalities. It provides a better security to the biker.

References:

- [1] International Journal of Science and Research (IJSR) ISSN (Online): 23197064 Volume 3 Issue 3, March 2014
- [2] J. International Journal Of Computer Science And Applications Vol. 6, No.2, Apr 2013 ISSN: 0974-1011
- [3] Sayeed and A.Perrig, Secure Wireless Communications: Secret Keys through Multi-path, Proc.IEEE Intl Conf.Acoustics, Speech Signal Processing, pp. 3013-3016, Apr.2008
- [4] International Journal of Scientific Engineering Research Volume 2, Issue 12, December-2011 1 ISSN 2229-5518
- [5] Drunken driving protection system International Journal of Scientific Engineering Research Volume 2, Issue 12, December-2011 1 ISSN 2229-5518
- [6] Vehicle accident alert and locator International Journal of Electrical Computer Sciences IJECS-IJENS Vol: 11 No: 02