

AC/AC convertor using DC-modulation for single phase induction motor

¹Anshul S. Wasnik, ²R. M. Bhombe², ³Manish Agrawal, ⁴Akshay Pillewan, ⁵Diksha Khare

¹M. Tech, Electrical Engg. (Power Electronics & Power System) Maharashtra, India,

²Asso. Prof., Department of Electrical Engg. GNIET, Nagpur, Maharashtra, India,

^{3,4,5}Assi. Prof., Department of Electrical Engg. GNIET, Nagpur, Maharashtra, India

Abstract- This article discusses the concept, design and computation of an AC/AC convertor specifically developed for driving single-phase induction motors, also known as split-phase motors, using DC modulation. Traditional AC/AC convertors face limitations in terms of output frequency and total harmonic distortion (THD). To address these limitations, a new type of AC/AC convertor based on DC modulation has been introduced. This innovative convertor offers improved power factor (p.f.), higher power transmission efficiency, and is suitable for driving single-phase induction motors. The effectiveness of the design is verified through simulation results, which demonstrate the successful implementation of a DC-modulated single-stage induction motors.

Index Terms- DC-modulation, Power factor correction, total harmonic distortion (THD), single phase induction motor

I. INTRODUCTION

Conventional AC/AC convertors have certain drawbacks, such as a lower output voltage compared to the input voltage, poor total harmonic distortion (THD), and the inability to match the output frequency with the input frequency using traditional voltage regulation methods like cycloconvertors and matrix convertors. To address these limitations, the innovative approach of employing DC-regulated AC/AC convertors has gained popularity. These convertors are effective in overcoming the aforementioned drawbacks.

Figure A illustrates a classic single-stage AC/AC convertor with voltage regulation technique and corresponding waveforms. When considering a resistive load [1-4], the input supply voltage is

$$v_s(t) = \sqrt{2}V_s \sin \omega t \quad (1)$$

Where V_s is the rms value, ω is the input radian frequency, $\omega = 2\pi f = 100\pi$ ($f = 50\text{Hz}$). The power factor is given by [6].

$$PF = \frac{DPF}{\sqrt{1 + THD^2}} \quad (2)$$

Where the displacement power factor is $DPF = \cos\Phi_1$, where Φ_1 represents the phase angle of the fundamental harmonic component. It means that for firing angle α is 45° (i.e. Φ_1 is 45°), the typical values are that $DPF = \cos 45^\circ = 0.707$ and THD is 0.2831 (or 28.31%). Therefore, the power factor of $PF = 0.680$ is considered to be relatively low.

The DC/DC conversion topologies are generally known for their fast response time and high efficiency. Utilizing DC-modulation power factor correction in AC/AC conversion can lead to high PF. Figure 2 illustrates a DC modulated single-stage Buck-type AC/AC convertor. Assume the supply voltage is 240 Vrms. The DC-modulation operation requires two bidirectional switches, referred to as S_M and S_S . [5-10]

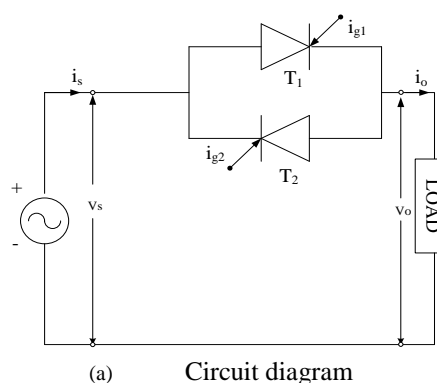

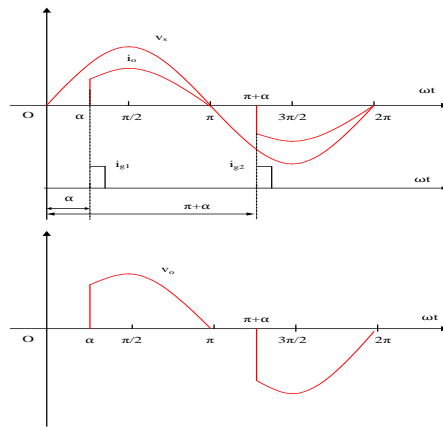

(b) Waveforms

Fig. 1 Conventional single stage AC/AC converter.

The DC-modulation frequency, denoted as f_m is typically set at a high value of 20 KHz ($f_m = 20 \text{ kHz}$). As a result, the input power supply voltage remains semi-static, either positive or negative, within a DC-modulation period of T_m , which is calculated as $1/f_m$ equaling $50 \mu\text{s}$. During AC/AC conversion it becomes necessary to incorporate a low-pass filter, $LS - CS$, on the input side. This is due to the fact that the input supply current of the Buck Converter operates in the form of a pulse train.

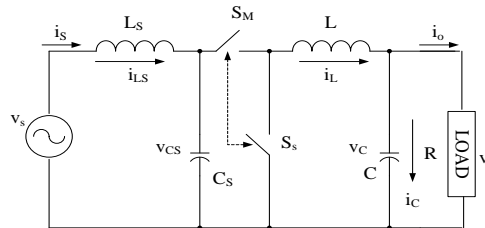
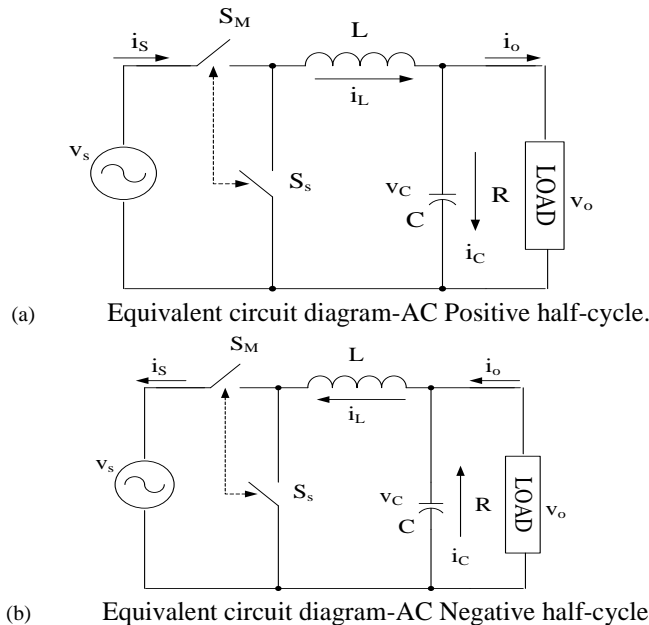

Fig. 2 Buck type DC-modulated AC/AC converter.

II. DC-MODULATED SINGLE – STAGE BUCK – TYPE AC/AC CONVERTER

In organize to consider the operation of AC/AC converter both positive and negative half-cycle of the input supply voltage considered for procedure. In the positive half-cycle of input supply voltage.



(a) Equivalent circuit diagram-AC Positive half-cycle.

(b) Equivalent circuit diagram-AC Negative half-cycle.

Fig. 3 Buck type DC-modulated AC/AC converter.

The equivalent circuit is given in Fig. 3 (a) The output voltage is calculated by

$$v_o = kv_s = k\sqrt{2}V_s \sin \omega t \quad 0 \leq \omega t < \pi \quad (3)$$

In the negative half-cycle of input supply voltage. The equivalent circuit is given in Fig 3 (b). The output voltage is calculate by

$$v_o = -k|v_s| = k\sqrt{2}V_s \sin \omega t \quad \pi \leq \omega t < 2\pi \quad (4)$$

Combine two state operations gives the whole-cycle operation.

$$v_o = kv_s = k\sqrt{2}V_s \sin \omega t \tag{5}$$

The input/output voltage whole cycle waveform is given in Fig. 4 and input/output current waveform is given in Fig. 5 Voltage transfer gain versus duty cycle $k = 0.75$ is given in Fig. 6 For different duty cycle the output voltage/current/power will be with high PF and high efficiency.

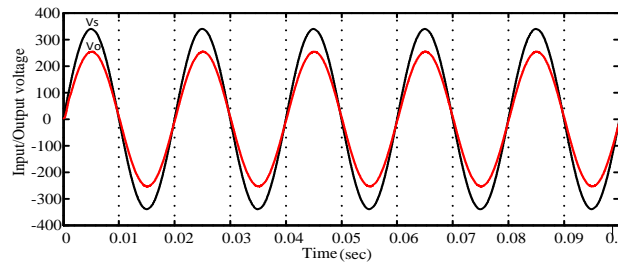

Fig. 4 Input/ Output voltage waveform of AC/AC converter with DC-modulation

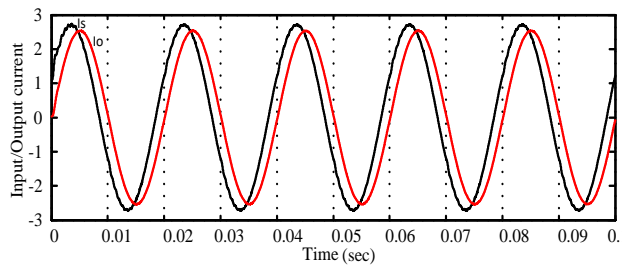

Fig. 5 Input/Output current waveform of AC/AC converter with DC-modulation.

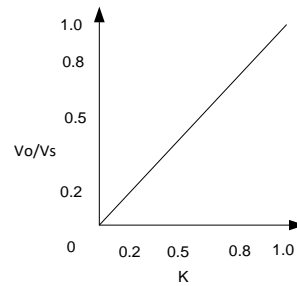
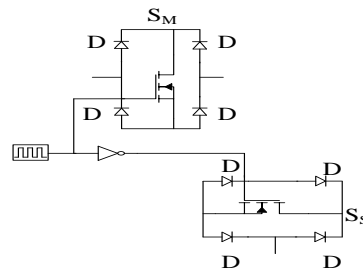

Fig. 6 The voltage transfer gain (v_o/v_s) versus duty cycle (K).

III. BIDIRECTIONAL EXCLUSIVE SWITCHES $S_M - S_S$

The AC/AC conversion with DC-modulation method requires bidirectional switches. The switch can be MOSFETs and IGBTs. The technical features of bidirectional switches $S_M - S_S$ are:

1. The master switch S_M conduct the forwardly flow current in the positive input voltage and also conduct the reversely flow current in the negative input voltage. The master switch always prohibited by a PWM pulse-train.
 2. The slave switch S_S switches on when master switch S_M switched-off exclusively. It provides free-wheeling action.
- The bidirectional select switches S_M-S_S circuit configuration is given in Fig. 7 It prescribed by a PWM pulse-train having adjustable frequency f_m and pulse-width. The time period $T_m = 1/f_m$ and the conduction duty cycle calculated as $k = (\text{pulse width})/T_m$.



(a) A circuit of bidirectional exclusive switches S_M-S_S .

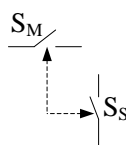

(b) A symbol of bidirectional exclusive switches S_M-S_S .
Fig. 7 DC-modulated bidirectional switches S_M-S_S operation.

IV. MATHEMATICAL MODELING OF DC/DC CONVERTERS.

According to Luo and Ye [11-12], the points for the design of DC/DC converter are given as follows:

1. The input pumping energy is PE.

$$PE = \int_0^{T_m} V_S i_S(t) dt = V_S \int_0^{T_m} i_s(t) dt = V_S I_S T_m \quad (6)$$

Where the average input supply current

$$I_s = \frac{1}{T_m} \int_0^{T_m} i_s(t) dt$$

2. The inductor stored energy is

$$W_L = \frac{1}{2} L I_L^2 \quad (7)$$

The capacitor stored energy is

$$W_C = \frac{1}{2} C V_C^2 \quad (8)$$

Therefore, the total stored energy (SE) in a DC/DC converter for n_L inductors and n_C capacitors is

$$SE = \sum_{j=1}^{n_L} W_{Lj} + \sum_{j=1}^{n_C} W_{Cj} \quad (9)$$

3. The energy factor EF is,

$$EF = \frac{SE}{PE} = \frac{SE}{V_S I_S T_m} = \frac{\sum_{j=1}^{n_L} W_{Lj} + \sum_{j=1}^{n_C} W_{Cj}}{V_S I_S T_m} \quad (10)$$

4. The capacitor/inductor stored energy (CIR) is define as,

$$CIR = \frac{\sum_{j=1}^{n_C} W_{Cj}}{\sum_{j=1}^{n_L} W_{Lj}} \quad (11)$$

5. The time constant τ :

$$\tau = \frac{2T_m \times EF}{1 + CIR} \left(1 + CIR \frac{1 - \eta}{\eta}\right) \quad (12)$$

6. The damping time constant

$$\tau_d = \frac{2T_m \times EF}{1 + CIR} \left(\frac{CIR}{\eta + CIR(1 - \eta)}\right) \quad \text{With } \tau_d = \zeta \tau \quad (13)$$

7. A DC/DC converter has the transfer function

$$G(s) = \frac{M}{1 + s\tau + s^2 \tau \tau_d} = \frac{M}{1 + s\tau + s^2 \tau^2 \xi} \quad (14)$$

Where M is the voltage transfer gain and $M = k$ for a Buck converter. The above model described with considering Buck converter having $L = 10 \text{ mH}$, $C = 3 \mu\text{F}$, the load $R = 100 \Omega$, input voltage and current are V_S and I_S , output voltage and current are V_o and I_o , no power losses, i.e. $\eta = 1$. The following obtain data as given by:

$$v_o = k v_S \quad i_S = k i_o$$

$$v_o = R i_o \quad P_{in} = v_S i_S = v_o i_o = P_o \quad \text{With } \eta = 1$$

$$PE = \int_0^{T_m} V_S i_S(t) dt = V_S \int_0^{T_m} i_s(t) dt = V_S I_S T_m$$

$$W_L = \frac{1}{2} L I_o^2$$

$$W_C = \frac{1}{2} C V_o^2$$

$$SE = \frac{1}{2} L I_o^2 + \frac{1}{2} C V_o^2$$

$$EF = \frac{SE}{PE} = \frac{L/R + CR}{2T_m}$$

$$\tau = \frac{2T_m \times EF}{1 + CIR} = \frac{L/R + RC}{1 + CIR} = 300.75\mu s$$

$$\tau_d = \frac{2T_m \times EF}{1 + \frac{1}{CIR}} = 99.24\mu s$$

Hence the transfer function is given as

$$G(s) = \frac{M}{1 + s\tau + 2s^2\tau} \tag{15}$$

The transfer function in equation (12) having two folded poles so the step-response will faster in time domain.

$$g(t) = M[1 - e^{-\frac{t}{2\tau_d}} (\cos \omega t - \frac{1}{\sqrt{4\tau_d/\tau - 1}} \sin \omega t)] \tag{16}$$

The power supply time period $T = 1/f = 20ms$ and the settling time period from one steady state to another one is $3\tau = 0.0902ms$ which is much lesser than the supply time period.

V. SINGLE PHASE INDUCTION MOTOR

A single phase induction motor having limitations of poor starting torque. To make the motor self start some arrangements are required so that motor can produce starting torque. The methods for self starting of single phase induction motor is providing an extra winding such as auxiliary winding on the stator side in addition with main winding and motor start as a two phase machine. The main winding and auxiliary winding in stator are phase displaced by 90°. The current in main winding and auxiliary winding are phase shift from each other, result is stator field generate the starting torque and motor behave as a balanced two phase motor.

In split phase induction motor main winding generally having high reactance but low resistance and auxiliary winding has low reactance but high resistance. The auxiliary winding having high resistance to low reactance ratio obtained by using reasonable wire because the auxiliary winding use in the circuit only during starting period. In auxiliary winding the switch is connected in series and disconnected at about 75% of synchronous speed. Split phase induction motor has low to moderate starting torque which depends on main and auxiliary winding current and phase angle between them.

VI. SIMULATION RESULTS AND ANALYSIS

The single phase induction motor (split phase) connection with AC supply consider for simulation as shown in Fig. 8

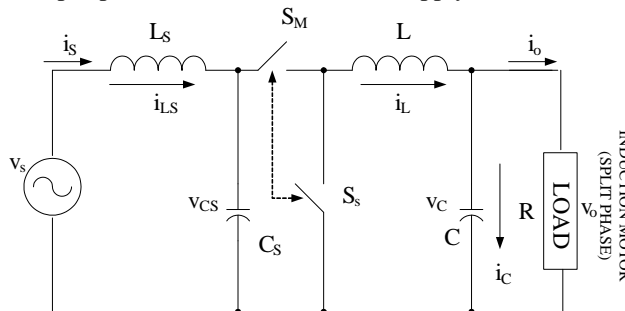

Fig. 8 Simulation circuit of induction motor with AC supply.

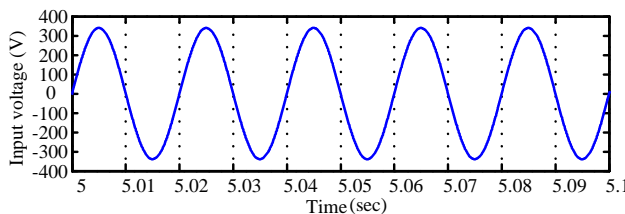

Fig. 9 Input voltage waveform of AC/AC converter with DC-modulation.

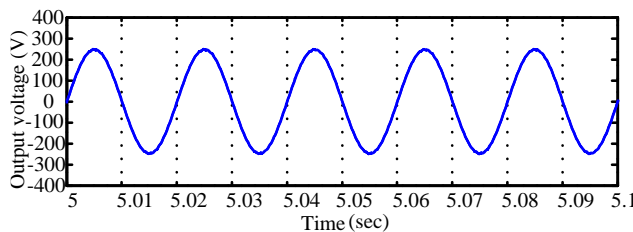

Fig.10 Output voltage waveform of AC/AC converter with DC-modulation.

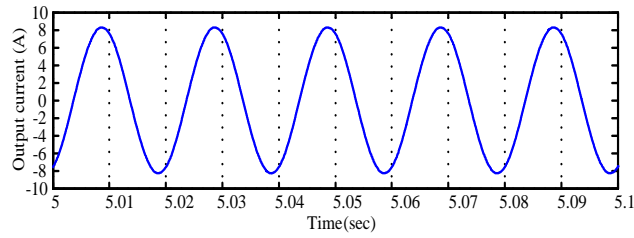

Fig. 11 Output current waveform of AC/AC converter with DC-modulation

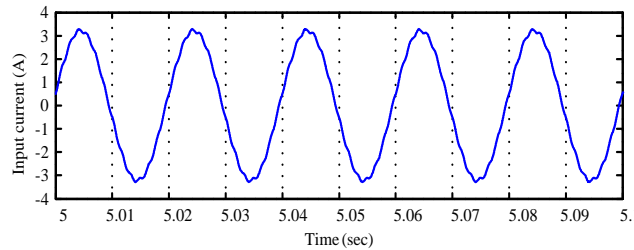

Fig. 12 Input current waveform of AC/AC converter with DC-modulation.

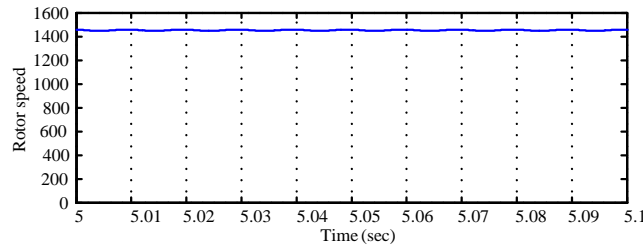

Fig. 13 Single phase induction machine speed.

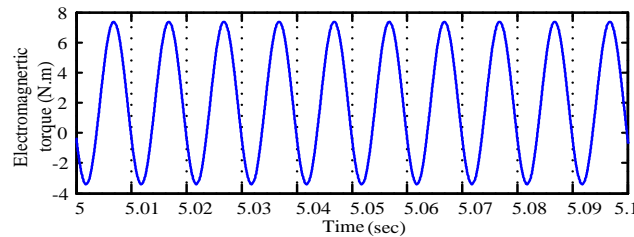

Fig. 14 Single phase induction machine Electromagnetic torque.

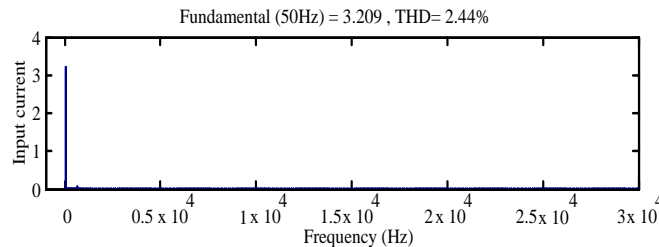

Fig. 15 Harmonic analysis of input current.

The Buck-type DC-modulated AC/AC converter for single phase induction motor drive having following components selected for simulation:

DC-modulated AC/AC converter components: $L_s = 1\text{mH}$, $C_s = 60\mu\text{F}$, $L = 10\text{mH}$, $C = 3\mu\text{F}$ and the duty cycle is selected as $k = 0.75$. Single phase Induction machine parameters: 1hp, 240V, 50Hz.

The simulation result of AC/AC converter input voltage $V_s = 240\text{ Vrms}$ is given in Fig. 9 and output voltage $V_o = 180\text{ Vrms}$ is given in Fig. 10. The input supply voltage and output voltage having frequency $f = 50\text{Hz}$. and there is not any phase delay between output voltage and input voltage. The simulation result of AC/AC converter output current $I_o = 6.016\text{ A}$ is given in Fig. 11. The input current

$I_s = 2.305$ A of AC/AC converter is given in Fig. 12. And input current leading with input voltage thus the Induction motor drive with DC-modulated AC/AC converter is operating at leading power factor. The induction motor speed is found to be 1458 rpm as given in Fig. 13. And the torque in split phase operation mode is given in Fig. 14. The load torque is 2 N.m. The torque ripple amplitude is 7.4 N.m.

The simulation results with consideration of power losses in the converter. The input power $P_{in} = 536.5$ W and the converter output power $P_o = 450.9$ W. The power transfer efficiency $\eta = P_o/P_{in} = 84.04\%$. And the simulation results shows that the final PF = 0.9851. If no power losses in an ideal condition converter input power $P_{in} = 459.6$ W and the converter output power $P_o = 451.3$ W. The power transfer efficiency $\eta = P_o/P_{in} = 98.19\%$. And the simulation results shows that the final PF = 0.9835. The spectrum of input current obtained with little distortion at from the harmonic component I_M at 20 kHz and much far away from a fundamental component I_s at 50 Hz. The parameters obtained as THD = 2.44%, DPF = 0.9854 and the final PF = 0.9851 is given in Fig. 15

VII. CONCLUSION

The DC-modulated power factor correction AC/AC converter can be use to drive single phase induction motor. It also overcomes the disadvantage of traditional AC/AC converters as high total harmonic distortion, poor power factor and poor power transfer efficiency. The DC-modulate AC/AC converter successfully improved the power factor up to PF=0.9851 and the power transfer efficiency up to 84.04%.The simulation results verify the design and calculation of DC-modulated single stage buck type AC/AC converter for single phase induction motor drive.

REFERENCES:

1. Rashid M. H., "Power Electronics Handbook" Academic Press, San Diego, 2001, pp. 307-334.
2. Mohan N., Undeland T. M. and Robbins W. P., "Power Electronics" 3-ed, John Wiley & Sons, USA, 2003, pp 42-43.
3. Cheng K. W. E., "Storage energy for classical switched mode power converters" Proceedings of IEE-EPA, Vol. 150, No. 4, 2003, pp.439-446.
4. Luo F. L., and Ye H., "Advanced DC/DC Converters" CRC Press LLC, Boca Raton, Florida, USA, 2004.
5. Luo F. L. and Ye H. "Research on DC-Modulated Power Factor Correction AC/AC Converters" IEEE-Proceedings on IECON, November5-8, 2007, Taipei, Taiwan, pp. 1478-1483.
6. Luo F. L., Ye H. and Rashid, "Digital Power Electronics and Applications" Academic Press, San Diego, USA, 2005.
7. Luo F. L. and Ye H. "Positive Output Super-Lift Luo-Converters" Proceedings of IEEE-PESC'2002, Cairns, Australia, 23-27 June 2002, pp. 425-430.
8. Luo F. L. and Ye H. "Negative Output Super-Lift Luo-Converters" Proceedings (CD-ROM) of IEEE International Conference PESC'03, Acapulco, Mexico, June15-19, 2003, pp.1361-1366.
9. Luo F. L. and Ye H. "Negative Output Super-Lift Converters" IEEE-Transactions on Power Electronics, Vol. 18, No. 5, September 2003, pp. 1113-1121.
10. Luo F. L. and Ye H. "Positive Output Cascade Boost Converters" IEE-EPA Proceedings, Vol. 151, No. 5, September2004, pp. 590-606.
11. Luo F. L. and Ye H. "Small Signal Analysis of Energy Factor and Mathematical Modeling for Power DC/DC Converters" IEEE-Trans. on PE, Vol. 22, No. 1, January 2007, pp. 69-79.
12. Luo F. L. and Ye H. "Energy Factor and Mathematical Modeling for Power DC/DC Converters" IEE-Proceedings on EPA Vol. 152, No. 2, March 2005, pp. 191-198.
13. Sen P.C., "Principles of Electric Machines And Power Electronics Handbook" Academic Press, John Wiley and Sons, 1997, pp. 374-417.